

# Superseded

# by a later version of this document

**PacketCable™**

## **Business SIP Services (BSS) Feature Specification**

**PKT-SP-BSSF-I02-100120**

**ISSUED**

### **Notice**

This PacketCable specification is the result of a cooperative effort undertaken at the direction of Cable Television Laboratories, Inc. for the benefit of the cable industry and its customers. This document may contain references to other documents not owned or controlled by CableLabs. Use and understanding of this document may require access to such other documents. Designing, manufacturing, distributing, using, selling, or servicing products, or providing services, based on this document may require intellectual property licenses from third parties for technology referenced in this document.

Neither CableLabs nor any member company is responsible to any party for any liability of any nature whatsoever resulting from or arising out of use or reliance upon this document, or any document referenced herein. This document is furnished on an "AS IS" basis and neither CableLabs nor its members provides any representation or warranty, express or implied, regarding the accuracy, completeness, noninfringement, or fitness for a particular purpose of this document, or any document referenced herein.

© Copyright 2008-2010 Cable Television Laboratories, Inc.  
All rights reserved.

## Document Status Sheet

<b>Document Control Number:</b>	PKT-SP-BSSF-I02-100120			
<b>Document Title:</b>	Business SIP Services (BSS) Feature Specification			
<b>Revision History:</b>	I01 – 09/05/2008 I02 - 01/20/2010			
<b>Date:</b>	January 20, 2010			
<b>Status:</b>	<del>Work in Progress</del>	Draft	Issued	<del>Closed</del>
<b>Distribution Restrictions:</b>	<del>Author Only</del>	<del>CL/Member</del>	<del>CL/Member/ Vendor</del>	Public

### Key to Document Status Codes

- Work in Progress**     An incomplete document, designed to guide discussion and generate feedback, that may include several alternative requirements for consideration.
  
- Draft**                     A document in specification format considered largely complete, but lacking review by Members and vendors. Drafts are susceptible to substantial change during the review process.
  
- Issued**                     A stable document, which has undergone rigorous member and vendor review and is suitable for product design and development, cross-vendor interoperability, and for certification testing.
  
- Closed**                     A static document, reviewed, tested, validated, and closed to further engineering change requests to the specification through CableLabs.

### Trademarks:

CableLabs®, DOCSIS®, EuroDOCSIS™, eDOCSIS™, M-CMTS™, PacketCable™, EuroPacketCable™, PCMM™, CableHome®, CableOffice™, OpenCable™, OCAP™, CableCARD™, M-Card™, DCAS™, tru2way™, and CablePC™ are trademarks of Cable Television Laboratories, Inc.

# Contents

<b>1</b>	<b>SCOPE</b> .....	<b>1</b>
1.1	Introduction and Purpose .....	1
1.2	Requirements .....	1
<b>2</b>	<b>REFERENCES</b> .....	<b>2</b>
2.1	Normative References .....	2
2.2	Informative References.....	3
2.3	Reference Acquisition .....	4
<b>3</b>	<b>TERMS AND DEFINITIONS</b> .....	<b>5</b>
<b>4</b>	<b>ABBREVIATIONS AND ACRONYMS</b> .....	<b>6</b>
<b>5</b>	<b>OVERVIEW</b> .....	<b>8</b>
5.1	PacketCable Design Considerations .....	8
5.2	Minimal set of UE capabilities .....	8
<b>6</b>	<b>BUSINESS SIP SERVICES (BSS) GENERAL REQUIREMENTS</b> .....	<b>11</b>
6.1	Relationship to RSTF .....	11
6.2	Minimum UE Profile .....	11
6.3	BSS AS Requirements.....	12
6.3.1	<i>Preventing Forwarding Loops and Limiting the Number of Forwarding Attempts</i> .....	12
6.4	Common Requirements .....	12
6.4.1	<i>Initiating a Call or Feature via Dial String</i> .....	12
6.4.2	<i>Early Media</i> .....	12
6.4.3	<i>Customized Alerting</i> .....	14
6.4.4	<i>Auto-Answer</i> .....	14
6.5	Quality of Service.....	14
<b>7</b>	<b>BUSINESS SIP SERVICES (BSS) FEATURE REQUIREMENTS</b> .....	<b>16</b>
7.1	Caller ID .....	16
7.1.1	<i>Calling Name and Number Delivery</i> .....	16
7.1.2	<i>Caller ID Per-Line Blocking</i> .....	17
7.1.3	<i>Caller ID Per-Call Blocking (CIDS-Suppression)</i> .....	17
7.1.4	<i>Caller ID Per-Call Delivery (CIDS-Delivery)</i> .....	18
7.1.5	<i>Caller ID with Call Waiting (CIDCW)</i> .....	18
7.1.6	<i>Anonymous Call Rejection</i> .....	18
7.2	Call Forwarding .....	19
7.2.1	<i>Call Forwarding General</i> .....	19
7.2.2	<i>Call Forwarding Variable (CFV)</i> .....	19
7.2.3	<i>Call Forwarding Don't Answer (CFDA)</i> .....	20
7.2.4	<i>Call Forwarding on Busy Line (CFBL)</i> .....	20
7.2.5	<i>Selective Call Forwarding (SCF)</i> .....	21
7.2.6	<i>Remote Activation of Call Forwarding</i> .....	22
7.2.7	<i>Call Forwarding to Voice Mail</i> .....	22
7.2.8	<i>Call Forwarding Endpoint/Network Not Available (CFNA)</i> .....	22
7.3	Call Blocking Features .....	22
7.3.1	<i>Outbound Call Blocking</i> .....	22
7.3.2	<i>Collect Call Blocking</i> .....	23
7.3.3	<i>Selective Call Acceptance (White List)</i> .....	23
7.3.4	<i>Selective Call Rejection (Black List)</i> .....	23
7.4	Multi-Party Features .....	23
7.4.1	<i>Call Waiting</i> .....	23

7.4.2	<i>Call Hold</i> .....	24
7.4.3	<i>Music on Hold</i> .....	24
7.4.4	<i>Consultation Hold</i> .....	25
7.4.5	<i>Call Transfer</i> .....	25
7.4.6	<i>Three-Way Calling</i> .....	34
7.4.7	<i>Multi-Party Conference Calling</i> .....	34
7.5	<b>Call History Features</b> .....	35
7.5.1	<i>Automatic Recall (Last Call Return)</i> .....	35
7.5.2	<i>Automatic Callback</i> .....	38
7.5.3	<i>Last Number Redial</i> .....	38
7.6	<b>Miscellaneous Features</b> .....	38
7.6.1	<i>Do Not Disturb (DND Client)</i> .....	38
7.6.2	<i>Do Not Disturb (DND Public Identity)</i> .....	39
7.6.3	<i>Screening List Editing (SLE)</i> .....	39
7.6.4	<i>Subscriber Programmable PIN</i> .....	40
7.6.5	<i>Distinctive Alerting</i> .....	40
7.6.6	<i>Message Waiting Indicators</i> .....	40
7.6.7	<i>Speed Dialing</i> .....	41
7.6.8	<i>Customer-Originated Call Trace</i> .....	41
7.7	<b>Operator Services</b> .....	42
7.8	<b>Emergency Services</b> .....	42
7.8.1	<i>Assumptions</i> .....	42
7.8.2	<i>Emergency Calling</i> .....	43
7.8.3	<i>Location Identification</i> .....	44
7.8.4	<i>SIP Location Conveyance</i> .....	44
7.8.5	<i>Media and Signaling QoS for an Emergency Call</i> .....	44
7.9	<b>Business-Oriented Individual Line Feature</b> .....	44
7.9.1	<i>Automated Attendant (Auto-attendant)</i> .....	44
7.9.2	<i>Direct Inward Dialing, Direct Outward Dialing (DID/DOD)</i> .....	45
7.9.3	<i>Extension Dialing (Private Numbering Plan)</i> .....	45
7.9.4	<i>Alternate Number (Virtual Number, Second Number)</i> .....	46
7.9.5	<i>Intercom (Group Intercom, Push-to-talk)</i> .....	46
7.9.6	<i>Shared Call Appearance (Multiple Appearance Directory Number – MADN)</i> .....	47
7.9.7	<i>Shared Call Appearance Bridging (Multi-Location Shared-Line Appearance)</i> .....	55
7.9.8	<i>Sequential Ring</i> .....	56
7.9.9	<i>Simultaneous Ring</i> .....	57
7.9.10	<i>Call Push, Call Pull (Call Jump)</i> .....	57
7.10	<b>Business-Oriented Group Line Features</b> .....	62
7.10.1	<i>Account Codes</i> .....	62
7.10.2	<i>Authorization Codes</i> .....	63
7.10.3	<i>Hunting and Hunt Groups</i> .....	63
7.10.4	<i>Call Park and Directed Call Park</i> .....	64
7.10.5	<i>Call Pickup Features</i> .....	65
7.10.6	<i>Outbound Call Restriction (Calling Plan Outgoing)</i> .....	65
7.10.7	<i>Charge Number Service</i> .....	66
7.10.8	<i>Loudspeaker Paging</i> .....	66
7.11	<b>Third Party Call Control Features</b> .....	67
7.11.1	<i>Click-to-dial</i> .....	68
7.11.2	<i>Incoming Call Notification and Control</i> .....	68
7.11.3	<i>3PCC Call Hold/Retrieve</i> .....	69
7.11.4	<i>3PCC Call Transfer</i> .....	69
7.11.5	<i>3PCC Conferencing</i> .....	70
7.11.6	<i>3PCC Release Call</i> .....	70
7.11.7	<i>Remote Office (Satellite Office, Road Warrior)</i> .....	70
<b>ANNEX A</b>	<b>DEVICE REQUIREMENTS</b> .....	<b>71</b>

A.1	DTMF Transport.....	71
A.2	Monitoring and Management.....	71
<b>APPENDIX I</b>	<b>ACKNOWLEDGEMENTS .....</b>	<b>72</b>
<b>APPENDIX II</b>	<b>REVISION HISTORY .....</b>	<b>73</b>

## Figures

FIGURE 1 - CALL TRANSFER; CONSULTATIVE TRANSFER USING REPLACES.....	29
FIGURE 2 - CALL TRANSFER; CONSULTATIVE TRANSFER USING 3PCC.....	30
FIGURE 3 - CALL TRANSFER; BLIND TRANSFER USING REPLACES .....	31
FIGURE 4 - CALL TRANSFER; CONSULTATIVE TRANSFER USING 3PCC AND IDENTITY UPDATE .....	32
FIGURE 5 - CALL TRANSFER; INTERWORKING WITH OUT OF DIALOG REFER.....	33
FIGURE 6 - AUTOMATIC RECALL (AR); ACTIVATION AND EXECUTION .....	37
FIGURE 7 - SCA REGISTRATION PHASE.....	51
FIGURE 8 - SCA CALL ORIGINATION.....	52
FIGURE 9 - SCA CALL TERMINATION.....	53
FIGURE 10 - SCA CALL HOLD/RETRIEVE.....	54
FIGURE 11 - SCA BRIDGING.....	56
FIGURE 12 - CALL JUMP; INCOMING CALL TO CALL JUMP SUBSCRIBER .....	59
FIGURE 13 - CALL JUMP; CALL PULL USING REPLACES .....	60
FIGURE 14 - CALL JUMP; CALL PULL USING 3PCC TECHNIQUES .....	61
FIGURE 15 - LOUDSPEAKER PAGING.....	67
FIGURE 16 - INCOMING CALL NOTIFICATION AND CONTROL.....	69

## Tables

TABLE 1 - BSS FEATURES ENABLED BY MINIMUM PROFILE UE.....	9
TABLE 2 - AUTO ANSWER CAPABILITY DATA .....	14
TABLE 3 - MULTI-PARTY CONFERENCING FEATURE DATA .....	35
TABLE 4 - SHARED CALL APPEARANCE UE DATA .....	50
TABLE 5 - SHARED CALL APPEARANCE BRIDGING UE DATA.....	55
TABLE 6 - DTMF RELAY FEATURE DATA .....	71

This page left blank intentionally.

**Superseded****by a later version of this document**

## 1 SCOPE

### 1.1 Introduction and Purpose

This document specifies an implementation of common Business services in a PacketCable™ network with Session Initiation Protocol (SIP) based User Equipment (UEs). These features include the most commonly used Business services and capabilities, including Hunting, Shared Call Appearance, Extension dialing, Call Pickup, and Call Park.

The PacketCable network architecture uses SIP as the basis for call setup and teardown. Further, SIP is the foundation of the 3<sup>rd</sup> Generation Partnership Project (3GPP) IP Multimedia Subsystem (IMS) architecture, upon which the PacketCable architecture is based. SIP has been designed as a general purpose protocol for establishing and managing multimedia sessions. As a result, a feature can be implemented many different ways, each one using different SIP capabilities or different call flows, and assuming different functionality in each participating component in the system. Interoperability issues arise unless all components support the same implementation approach.

This specification defines the network requirements and signaling to enable User Equipment (UE) to establish services to emulate historical analog telephony services and features for businesses. Specifically it defines the key functionality expected of each participating component in the system.

### 1.2 Requirements

Throughout this document, the words that are used to define the significance of particular requirements are capitalized. These words are:

"MUST"	This word means that the item is an absolute requirement of this specification.
"MUST NOT"	This phrase means that the item is an absolute prohibition of this specification.
"SHOULD"	This word means that there may exist valid reasons in particular circumstances to ignore this item, but the full implications should be understood and the case carefully weighed before choosing a different course.
"SHOULD NOT"	This phrase means that there may exist valid reasons in particular circumstances when the listed behavior is acceptable or even useful, but the full implications should be understood and the case carefully weighed before implementing any behavior described with this label.
"MAY"	This word means that this item is truly optional. One vendor may choose to include the item because a particular marketplace requires it or because it enhances the product, for example; another vendor may omit the same item.

## 2 REFERENCES

### 2.1 Normative References

In order to claim compliance with this specification, it is necessary to conform to the normative requirements within the following standards and other works as indicated. This is in addition to the other requirements of this specification. Notwithstanding, intellectual property rights may be required to use or implement such normative references.

- [CMSS 1.5] PacketCable CMS to CMS Signaling 1.5 Specification, PKT-SP-CMSS1.5-I06-100120, January 20, 2010, Cable Television Laboratories Inc.
- [CODEC MEDIA] PacketCable Codec and Media Specification, PKT-SP-CODEC-MEDIA-I08-100120, January 20, 2010, Cable Television Laboratories, Inc.
- [GR 30] Telcordia GR-30-CORE, LSSGR: Voiceband Data Transmission Interface, December 1998, FR-64.
- [GR 570] Telcordia GR-570, LSSGR: Speed Calling (FSD 01-02-1101), June 2000, FR-64.
- [GR 571] Telcordia GR-571, LSSGR: Call Waiting (FSD 01-02-1201), June 2000, FR-64.
- [ID SIP-CONVEY] IETF Internet-Draft, Location Conveyance for the Session Initiation Protocol, draft-ietf-sipcore-location-conveyance-01, July 2009, work in progress.
- [ID JOHNSTON-BLISS-MLA] IETF Internet-Draft, The Multiple Appearance Feature using the Session Initiation Protocol (SIP), draft-johnston-bliss-mla-req-02, July 2008, work in progress. (<http://tools.ietf.org/html/draft-johnston-bliss-mla-req-02>)
- [ID MMUSIC-LOOPBACK] IETF Internet Draft, An Extension to the Session Description Protocol (SDP) for Media Loopback, draft-ietf-mmusic-media-loopback-11, October 2009, work in progress.
- [PKT 24.229] PacketCable Release Sip and SDP Stage 3 Specification 3GPP TS 24.229, PKT-SP-24.229-I06-100120, January 20, 2010, Cable Television Laboratories, Inc.
- [RFC 3261] IETF RFC 3261, SIP: Session Initiation Protocol, June 2002.
- [RFC 3262] IETF RFC 3262, Reliability of Provisional Responses in the Session Initiation Protocol (SIP), June 2002.
- [RFC 3264] IETF RFC 3264, An Offer/Answer Model with the Session Description Protocol (SDP), June, 2002.
- [RFC 3265] IETF RFC 3265, Session Initiation Protocol (SIP)-Specific Event Notification, June 2002.
- [RFC 3323] IETF RFC 3323, A Privacy Mechanism for the Session Initiation Protocol (SIP), November 2002.
- [RFC 3515] IETF RFC 3515, The Session Initiation Protocol (SIP) Refer Method, April 2003.
- [RFC 3680] IETF RFC 3680, A Session Initiation Protocol (SIP) Event Package for Registrations, March 2004.
- [RFC 3825] IETF RFC 3825, Dynamic Host Configuration Protocol Option for Coordinate-based Location Configuration Information, July 2004.
- [RFC 3911] IETF RFC 3911, The Session Initiation Protocol (SIP) "Join" Header, October 2004.
- [RFC 3959] IETF RFC 3959, The Early Session Disposition Type for the Session Initiation Protocol (SIP), December, 2004.
- [RFC 4235] IETF RFC 4235, An INVITE-Initiated Dialog Event Package for the Session Initiation Protocol (SIP), November 2005.
- [RFC 4244] IETF RFC 4244, An Extension to the Session Initiation Protocol (SIP) for Request History Information, November 2005.
- [RFC 4458] IETF RFC 4458, Session Initiation Protocol (SIP) URIs for Applications such as Voicemail and Interactive Voice Response (IVR), April 2006.

- [RFC 4538] IETF RFC 4538, Request Authorization through Dialog Identification in the Session Initiation Protocol (SIP), June 2006.
- [RFC 4676] IETF RFC 4676, Dynamic Host Configuration Protocol (DHCPv4 and DHCPv6) Option for Civic Addresses Configuration Information, October 2006.
- [RFC 4967] IETF RFC 4967, Dial String Parameter for the Session Initiation Protocol Uniform Resource Identifier, July 2007.
- [RFC 5031] IETF RFC 5031, A Uniform Resource Name (URN) for Emergency and Other Well-Known Services, January 2008.
- [RFC 5079] IETF RFC 5079, Rejecting Anonymous Requests in the Session Initiation Protocol (SIP), December 2007.
- [RFC 5627] IETF RFC 5627, Obtaining and Using Globally Routable User Agent URIs (GRUUs) in the Session Initiation Protocol (SIP), October 2009.
- [RSTF] PacketCable Residential SIP Telephony Specification, PKT-SP-RSTF-I06-100120, January 20, 2010, Cable Television Laboratories, Inc.
- [TS 32.260] 3GPP TS 32.260, IP Multimedia Subsystem (IMS) charging, Release 7, V7.4.0 (2007-09).

## 2.2 Informative References

This specification uses the following informative references.

- [ARCH-FRM TR] PacketCable Architecture Framework Technical Report, PKT-TR-ARCH-FRM-V06-090528, May 28, 2009, Cable Television Laboratories, Inc.
- [BSS TR] PacketCable Business SIP Services (BSS) Feature Description Technical Report, PKT-TR-BSS-V01-080905, September 5, 2008, Cable Television Laboratories, Inc.
- [E-DVA] PacketCable Residential SIP Telephony E-DVA Specification, PKT-SP-RST-E-DVA-I06-100120, January 20, 2010, Cable Television Laboratories, Inc.
- [GR 569] Telcordia GR-569, LSSGR: Multiline Hunt Service (FSD 01-02-0802), June 2000, FR-64.
- [GR 579] Telcordia GR-579, LSSGR: Add-On Transfer and Conference Calling Feature (FSD 01-02-1305), June 2000, FR-64.
- [GR 581] Telcordia GR-581, LSSGR: Remote Call Forwarding (FSD 01-02-1402), June 2000, FR-64.
- [NENA i2] NENA, Interim VoIP Architecture for Enhanced 9-1-1 Services (i2), NENA 08-001, Issue 1 December 6, 2005.  
[http://www.nena.org/sites/default/files/08-001\\_20051205.pdf](http://www.nena.org/sites/default/files/08-001_20051205.pdf)
- [NENA i3] NENA Functional and Interface Standards for Next Generation 9-1-1 Version 1.0 (i3), NENA 08-002, Version 1.0, December 18, 2007.  
<http://www.nena.org/sites/default/files/08-002%20V1%2020071218.pdf>
- [RFC 3725] IETF RFC 3725, Best Current Practices for Third Party Call Control (3PCC) in the Session Initiation Protocol (SIP), April 2004.
- [RFC 3891] IETF RFC 3891, The Session Initiation Protocol (SIP) Replaces Header, September 2004.
- [RFC 3960] IETF RFC 3960, Early Media and Ringing Tone Generation in the Session Initiation Protocol (SIP), December 2004.
- [RFC 3966] IETF RFC 3966, The tel URI for Telephone Numbers, December 2004.
- [RFC 4119] IETF RFC 4119, A Presence-based GEOPRIV Location Object Format, December 2005.
- [RFC 4566] IETF RFC 4566, SDP: Session Description Protocol, July 2006.
- [RFC 4579] IETF RFC 4579, Session Initiation Protocol (SIP) Call Control - Conferencing for User Agents, August 2006.

- [RFC 5373] IETF RFC 5373, Requesting Answering Modes for the Session Initiation Protocol (SIP), November 2008.
- [TS 24.147] 3GPP TS 24.147, Conferencing using the IP Multimedia (IM) Core Network (CN) subsystem; Stage 3, Release 7, V7.9.0 (2008-06).

## 2.3 Reference Acquisition

- 3rd Generation Partnership Project: [www.3gpp.org](http://www.3gpp.org)
- Cable Television Laboratories, Inc., 858 Coal Creek Circle, Louisville, CO 80027; Phone +1-303-661-9100; Fax +1-303-661-9199; Internet: <http://www.cablelabs.com/>
- Internet Engineering Task Force (IETF), Internet: <http://www.ietf.org/>  
Note: Internet-Drafts are draft documents valid for a maximum of six months and may be updated, replaced, or obsoleted by other documents at any time.  
The list of current Internet-Drafts can be accessed at <http://www.ietf.org/ietf/1id-abstracts.txt>.  
Internet-Drafts may also be accessed at <http://tools.ietf.org/html/>
- National Emergency Number Association (NENA),  
[http://www.nena.org/9-1-1TechStandards/tech\\_info\\_docs.htm](http://www.nena.org/9-1-1TechStandards/tech_info_docs.htm), <http://www.nena.org/9-1-1TechStandards/voip.htm>
- Telcordia Technologies, <http://www.telcordia.com/>

### 3 TERMS AND DEFINITIONS

This specification uses the following terms:

**RST Capable UE**      A UE implementation that conforms to all of the normative requirements within [RSTF].

## 4 ABBREVIATIONS AND ACRONYMS

This specification uses the following abbreviations:

<b>3WC</b>	Three Way Calling
<b>AC</b>	Automatic Callback
<b>ACR</b>	Anonymous Call Rejection
<b>AR</b>	Automatic Recall
<b>AS</b>	Application Server
<b>B2BUA</b>	Back-to-Back User Agent
<b>BSS</b>	Business SIP Services
<b>CF</b>	Call Forwarding
<b>CFBL</b>	Call Forwarding Busy Line
<b>CFDA</b>	Call Forwarding Don't Answer
<b>CFV</b>	Call Forwarding Variable
<b>CIDS</b>	Caller Identity Delivery and Suppression
<b>CM</b>	Cable Modem
<b>CMTS</b>	Cable Modem Termination System
<b>CNAMD</b>	Calling Name Delivery
<b>CND</b>	Calling Number Delivery
<b>COT</b>	Customer Originated Trace
<b>CPE</b>	Customer Premise Equipment
<b>DND</b>	Do Not Disturb
<b>DSCP</b>	Differentiated Services Code Point
<b>DTMF</b>	Dual Tone Multi Frequency
<b>E-CSCF</b>	Emergency-Call Session Control Function
<b>GRUU</b>	Globally Routable User-Agent URI
<b>IETF</b>	Internet Engineering Task Force
<b>IMS</b>	IP Multimedia Subsystem
<b>IP</b>	Internet Protocol
<b>ITU</b>	International Telecommunication Union
<b>IVR</b>	Interactive Voice Responder
<b>LIDB</b>	Line Identification Database
<b>MGC</b>	Media Gateway Controller
<b>NAT</b>	Network Address Translation.
<b>NENA</b>	National Emergency Number Association
<b>P-CSCF</b>	Proxy - Call Session Control Function
<b>PIDF-LO</b>	A Presence Information Data Format Location Object
<b>PRACK</b>	Provisional Acknowledgement
<b>PSAP</b>	Public Safety Answering Point – the entity that answers 9-1-1 calls
<b>PSTN</b>	Public Switched Telephone Network
<b>QoS</b>	Quality of Service

---

<b>RACF</b>	Remote Activation of Call Forwarding
<b>RST</b>	Residential SIP Telephony
<b>RTP</b>	Real-time Transport Protocol
<b>SCF</b>	Selective Call Forwarding
<b>S-CSCF</b>	Serving – Call Session Control Function
<b>SDP</b>	Session Description Protocol, defined by [RFC 4566].
<b>SIP</b>	Session Initiation Protocol, VoIP signaling protocol, defined by [RFC 3261]
<b>SLE</b>	Screening List Editing
<b>UE</b>	User Equipment
<b>URI</b>	Uniform Resource Identifier
<b>URL</b>	Uniform Resource Locator
<b>URN</b>	Uniform Resource Name
<b>VoIP</b>	Voice over Internet Protocol
<b>VSC</b>	Vertical Service Code

## 5 OVERVIEW

The Business SIP Services (BSS) Feature Description Technical Report [BSS TR] contains full descriptions of all the BSS features. This specification complements [BSS TR] by describing how the BSS features are implemented using SIP in a PacketCable network, and defines requirements for the following elements:

**BSS User Equipment (UE):** The functional element subscribers use to attach to the PacketCable network. UEs may take any number of forms, including clients embedded into cable modems, clients embedded into set-top boxes, clients embedded into SIP Phones, and software clients on PCs or laptops. UEs support several interfaces to the PacketCable network:

- Signaling: For the creation, modification, and deletion of sessions.
- Media: For carrying audio or other media traffic, and related statistics.
- Network Address Translation (NAT) and Firewall Traversal: For permitting Business SIP Services features to operate through NAT and Firewall devices.
- Security: For securing interfaces.

A BSS UE is a PacketCable UE that implements the BSS features as specified in this document. The terms UE and BSS UE are used interchangeably in this document unless indicated otherwise.

**BSS Application Server (AS):** The Business SIP Services Application Server is a logical network component that implements some aspects of BSS features. The PacketCable architecture provides a framework for triggering SIP messages to the application server based on the service profile of a user.

The terms AS and BSS AS are used interchangeably in this document unless indicated otherwise.

### 5.1 PacketCable Design Considerations

The following design principles have been used in the creation of this specification.

- Align with current industry practice
 

Many SIP-based implementations of BSS features exist already for use in non-cable markets. This specification avoids inventing new ways of implementing features by aligning with current industry practice when it is reasonable to do so. This maximizes interoperability with current off-the-shelf UEs.
- Only including essential normative requirements
 

Often there are multiple equally acceptable ways of implementing a feature. This specification focuses on requirements that are essential for ensuring client/network interoperability or relate to unique aspects of a PacketCable network.
- Avoid placing any new requirements on the PacketCable Core network
 

The PacketCable core network, based upon IMS, is designed to support multiple applications. This specification avoids mandating changes to the core network and only places requirements on the BSS UE and BSS AS.

### 5.2 Minimal set of UE capabilities

To allow AS designers to implement features that are agnostic to the UE capabilities, a minimum UE profile is defined in Section 6.2. This profile has been chosen based upon generally accepted levels of support in UEs targeting the BSS market. It is anticipated that most UEs will exceed this minimum profile.

Table 1 summarizes the BSS features available to a UE supporting the minimum profile. The table is not normative, so if there is a discrepancy between the written text requirements and the table, the written text requirements take precedence. A feature is marked as being supported when the core operation of the feature is possible – some secondary aspects of the feature, for example, that improve the user experience, may require additional UE capabilities. A feature is marked as not being supported if the feature cannot operate without additional UE functionality.

**Table 1 - BSS features enabled by minimum profile UE**

<b>BSS Feature</b>	<b>Supported by Minimum Profile</b>	<b>Notes</b>
Calling Number/Name Delivery	No	See Section 7.1.1. Requires client capable of displaying number/name.
Caller ID Per-Line Blocking	Yes	Network feature
Caller ID Per-Call Blocking	Yes	Network feature
Anonymous Call Rejection	Yes	Network feature
Call Forwarding (all types)	Yes	Network feature
Outbound Call Blocking	Yes	Network feature
Collect Call Blocking	Yes	Network feature
Selective Call Acceptance/Rejection	Yes	Network feature
Call Waiting	Yes	Part of minimum profile
Call Hold	Yes	Part of minimum profile
Music On Hold	Yes	Network feature
Consultation Hold	Yes	Part of minimum profile
Call Transfer	Yes	Part of minimum profile
Three-Way Calling	No	See Section 7.4.6. Requires UE to connect participants to media mixing resource.
Multi-Party Conference Calling	No	See Section 7.4.7. Requires UE to connect participants to media mixing resource.
Automatic Recall (Last Call Return)	Yes	Network feature
Automatic Callback	Yes	Network feature
Last Number Redial	No	Client feature
Do Not Disturb Client	No	Client feature
Do Not Disturb Public User Identity	Yes	Network feature
Screen List Editing	Yes	Network feature
Subscriber Programmable PIN	Yes	Network feature
Distinctive Alerting	No	See Section 7.6.5. Requires client capable of providing distinctive alerting patterns.
Message Waiting Indicators	No	See Section 7.6.6. Requires client able to provide audible/visual Message Waiting Indicator.
Speed Dialing	Yes	Network feature
Customer-Originated Call Trace	Yes	Network feature
Fax, Modem and TDD Calls	No	Requires client is capable of connecting to fax/modem machine.
Busy Line Verification	No	See Section 7.7; requires support of the Join header.
Operator Interrupt	No	See Section 7.7; requires support of the Join header.

<b>BSS Feature</b>	<b>Supported by Minimum Profile</b>	<b>Notes</b>
Emergency Calling	Partial	Basic emergency call origination is possible when network detects emergency dial string (see Section 7.8), however UE must support additional functionality to ensure correct feature interactions.
Automated Attendant	Yes	Network feature
Direct Inward/Outward Dialing	Yes	Network feature
Extension Dialing	Yes	Network feature
Alternate Number	Yes	Network feature
Intercom	No	See Section 7.9.5. Requires client capable of automatically answering the call.
Shared Call Appearance	No	See Section 7.9.6. Requires feature-specific support in the client.
Shared Call Appearance Bridging	No	See Section 7.9.7. Requires feature-specific support in the client.
Sequential Ring	Yes	Network feature
Simultaneous Ring	Yes	Network feature
Call Push/Pull (Jump)	Yes	Network feature
Remote Office	Yes	Network feature
Account Codes	Yes	Network feature
Authorization Codes	Yes	Network feature
Hunting/Hunt Groups	Yes	Network feature
Call Park/Directed Call Park	Yes	Network feature
Call Pickup	Yes	Network feature
Outbound Call Restriction	Yes	Network feature
Charge Number Service	Yes	Network feature
Loudspeaker Paging	No	See Section 7.10.8. Requires client capable of automatically answering the call.
Third Party Call Control	Yes	Network feature

## 6 BUSINESS SIP SERVICES (BSS) GENERAL REQUIREMENTS

This section describes some general requirements that span across individual BSS features.

### 6.1 Relationship to RSTF

[RSTF] specifies an implementation of common residential telephony features in a PacketCable network with SIP based UEs providing an analog user interface. Most of the residential features have equivalent versions in BSS.

[RSTF] has been designed for UEs with analog interfaces and requires that the UE implements behavior not typically found in UE implementations developed for non-Cable markets. This specification provides an alternative implementation of these features suitable for a broader range of UEs.

An RST Capable UE **MUST** meet the requirements specified in [RSTF]. Additionally, a BSS UE that contains an embedded Cable Modem and supports an analog interface **MUST** meet the requirements specified in [RSTF]. If any discrepancy exists between requirements defined in [RSTF] and this specification, then [RSTF] takes precedence. For RST Capable UEs or UEs with embedded CMs, this specification is used for business features that do not have a residential equivalent.

For BSS features that have a residential equivalent specified in [RSTF], the BSS AS **MUST** interoperate with RST Capable UEs.

### 6.2 Minimum UE Profile

This section outlines the core set of specifications and functionality, which all BSS UEs are required to support (and an AS designer may assume is supported on the BSS UE).

The UE **MUST** comply with the following specifications:

- [RFC 3261] SIP
- [RFC 3262] Reliability of Provisional Responses
- [RFC 3264] An Offer/Answer Model
- [RFC 3515] Refer

In addition:

- The UE needs to meet the minimum requirements to connect to the core network. This is outside the scope of this specification and may be deployment-specific. For a PacketCable core network, this includes:
  - Support of SIP signaling as specified by [PKT 24.229].
  - Support of a suitable codec (e.g., G.711) as specified by [CODEC MEDIA].
- The UE **MUST** register with the network prior to initiating and receiving calls.
- The UE **MUST** support origination of voice calls identified using a dial string (see Section 6.4.1).
- The UE **MUST** support origination of calls with Early Media (see Section 6.4.2).
- The UE **MUST** support termination of voice calls.
- While an existing call is in progress:
  - The UE **MUST** allow Dual Tone Multi Frequency (DTMF) digits (0-9, \* and #) to be sent (see Section A.1).
  - The UE **MUST** support placing the existing call on hold and establishment of a second call (see Section 7.4.4).
  - The UE **MUST** allow an incoming call to be answered by placing the existing call on hold (see Section 7.4.1).

- The UE MUST allow the existing call to be transferred (see Section 7.4.5).

When placing media on hold, the UE MUST follow the procedures defined in [RSTF].

## 6.3 BSS AS Requirements

The BSS AS MUST comply with Application Server requirements defined in [PKT 24.229]. A BSS AS claiming to support a BSS feature MUST interoperate with a UE meeting the minimum profile defined in Section 6.2, unless operation of the feature requires additional UE capabilities as described in this specification.

### 6.3.1 Preventing Forwarding Loops and Limiting the Number of Forwarding Attempts

A number of BSS features require that the BSS AS automatically redirects a terminating call attempt to a new destination. A forwarding loop occurs when a targeted subscriber for a call forwards the call to another destination; if the forwarded-to destination also has call forwarding configured, the call can forward back (directly or indirectly) to the original targeted subscriber.

Although this scenario is associated with traditional Call Forwarding features (Section 7.2), it can occur with other forwarding-like features, such as Sequential Ringing (Section 7.9.8) and Simultaneous Ringing (Section 7.9.9).

If the BSS AS supports a feature that automatically redirects terminating call attempts to a new destination, then:

- The BSS AS MUST detect call forwarding loops.
- The BSS AS MUST support a configurable limit on the number of times an individual call may be subject to forwarding. If the number of forwarding attempts for a single call exceeds this limit, the BSS AS MUST NOT forward the call to another destination. The default behavior in this case is to reject the call.
- The BSS AS MUST support loop detection and forwarding limit detection via the use of History-Info header [RFC 4244] in such a way that is compatible with the mechanisms defined in [RSTF] and [CMSS 1.5].

## 6.4 Common Requirements

### 6.4.1 Initiating a Call or Feature via Dial String

Many BSS features are invoked when the user initiates a call from the UE with a particular dial string.

The UE MUST perform the collection of dial string. This requires that the UE can detect end-of-dialing. Precisely how the UE determines end-of-dialing is outside the scope of this specification, but will typically make use of one or more of the following techniques:

- A digit map is provisioned in the UE.
- An inter-digit timer expires.
- The user explicitly signaling end-of-dialing (for example, using a "make call" key or dialing "#").

The UE MUST support dial strings that include digits "0" to "9", "\*", and "#" at a minimum. Additional characters may be supported.

Unless the UE is provisioned to take a different action (for example, invoke a local feature when a particular dial string is entered), the UE MUST send an INVITE to the network with the Request URI containing the dial string formatted as the user-info portion of a SIP URI. The UE SHOULD include a dial string parameter as specified in [RFC 4967]. To interoperate with UEs that don't support [RFC 4967], the BSS AS MUST assume that a URI without any user parameter is actually a dial string.

### 6.4.2 Early Media

Early media is media exchanged before the call's full dialog is established, as described by [RFC 3960]. The media stream may be one- or two-way. The usual example of one-way media is ringback: A calls B, A hears ringtone from B via early media even before the SIP dialog is confirmed (which happens when B answers the call). An example of two-way media is DND PIN entry: A calls B, A is connected to an AS for collection of a PIN. The media stream is bi-directional; one stream to the AS for PIN digit reception, the other from the AS to request the entry of the PIN. In both examples, the call is not considered established as the SIP dialog initiating transaction is not complete.

In addition to establishing the media stream prior to establishing the session dialog, early media may involve several intermediate established media sessions called early session media. This form of media is necessary for features like Outbound Call blocking and anytime media is established with a secondary source prior to connection to the final terminator.

#### **6.4.2.1 Feature Execution, Early Media from Terminating Party**

Early media execution involves two parties in a basic call: the originator, who receives early media from the terminator upon receiving an 18X provisional response containing the Session Description Protocol (SDP), and the terminator, who sends early media after sending a positive response to a Provisional Acknowledgement (PRACK) from the originator.

A UE MUST support the PRACK method defined in [RFC 3262] and indicate such by populating the Supported header appropriately in all INVITE requests.

For the originator in the call:

- Early media may be received by the originator at any time after receiving an 18X provisional response from the terminator. The terminating UE sending the 18X provisional response for early media MUST include '100rel' in the Require header if the originating party indicated support for PRACK.
- The originating UE SHOULD only apply early media if both an SDP and Real-Time Transport Protocol (RTP) packets (from a source identified in the SDP) are received. Otherwise it is preferable to provide local ringback.
- Renegotiation of media by the UE may occur any time during an early dialog via UPDATE from the terminator.

For the terminator in the call:

- The terminating UE receiving a compatible SDP in the initial INVITE MUST send an 18X response with the negotiated codec. If the originating UE indicated support for PRACK by inclusion of a Supported header in the INVITE populated with a '100rel' option tag, then the terminating UE MUST require the use thereof by populating a Require header with '100rel' in the 18x response. This ensures that the response is reliable.
- When the terminating UE receives a PRACK, it SHOULD begin sending any available media to the originating UE. The terminating UE MAY begin sending any available media to the originating UE before receiving a PRACK.
- Renegotiation of media by the UE may occur at any time during an early dialog via UPDATE from the originator.

#### **6.4.2.2 Feature Execution, Early Media from Intermediate Parties**

Early session media may be used for playing announcements as an intermediate step before terminating to a UE. Examples include Outbound Call Blocking, etc.

For the originator in the call, in addition to normal early media execution:

- The UE SHOULD support early-session media offer answer as defined by [RFC 3959].
- If the UE indicated support for early-session (as defined by [RFC 3959]), and an early-session offer is received, the UE MUST send an early-session answer.

For the terminator in the call that is providing early media, in addition to early media execution as described in Section 6.4.2.1:

- The call terminator (usually the BSS AS) SHOULD support early-session media offer answer as defined by [RFC 3959]. The call terminator (usually the BSS AS) SHOULD send an early-session offer when the originator signals it supports early-session via population of the Supported header in the initial INVITE.

#### **6.4.2.3 Call Flows**

Refer to [RFC 3959] and [RFC 3960] for illustrative call flows.

### 6.4.3 Customized Alerting

A few BSS features require that the BSS AS signals to the UE that a customized alerting pattern is to be used for an incoming call. The Alert-Info header (defined by [RFC 3261]) is used to signal this in an INVITE but [RFC 3261] doesn't define valid values to put into the header.

If a features requires customized alerting:

- The BSS AS MUST support adding into an INVITE one of the baseline set of alert patterns given in [RSTF].
- The UE MUST recognize and support the baseline set of alert patterns given in [RSTF].

### 6.4.4 Auto-Answer

A few BSS features require that the UE is able to automatically answer incoming calls and play audio via its loudspeaker. Many UEs (e.g., with analog interfaces) are not able to support this capability and should not be used in conjunction with these features.

In this specification, the BSS AS determines the circumstances in which an incoming call should be automatically answered by the UE and signals this using the mechanism specified in [RFC 5373]. To prevent abuse of the auto-answer mechanism, the PacketCable network is expected to police usage of the header (e.g., at the trust boundary).

If the UE supports auto-answer and is not already engaged in a call, it MUST answer the call and play audio via its loudspeaker when an INVITE is received with Answer-Mode or Priv-Answer-Mode set to "Auto". When a Priv-Answer-Mode header set to "Auto" is received, the UE SHOULD attempt to answer calls even when it is busy.

Loopback streams (as defined in [ID MMUSIC-LOOPBACK]) are never played through the loudspeaker. If the UE supports [ID MMUSIC-LOOPBACK], then the loopback request MUST take precedence.

**Note:** The originator of the loopback test is expected to detect when a UE does not support [ID MMUSIC-LOOPBACK] and abandon the test.

When the BSS AS feature logic requires that a call is automatically answered, it MUST include an Answer-Mode or Priv-Answer-Mode header set to "Auto" in the INVITE sent towards the UE.

Refer to the individual features that make use of this capability for further details.

#### 6.4.4.1 Feature Data

Table 2 summarizes the feature data items defined for Auto-Answer.

**Table 2 - Auto Answer Capability Data**

Data	Type	UE Persistence	Scope	UE Provisioning
Auto Answer Mode	Boolean	Non-volatile	Per Business Group	Mandatory Writable

## 6.5 Quality of Service

PacketCable Business SIP Services utilize the Quality of Service (QoS) capabilities of the PacketCable architecture as defined in [ARCH-FRM TR]. In general, if QoS resources can't be allocated for a call, operator policy dictates whether the call is permitted to proceed or not. One operator may not permit calls for which QoS cannot be allocated to proceed while another operator may permit such calls. In the case of an emergency services call, or an operator services emergency interruption, the call may be attempted even if QoS resources cannot be allocated for the call, per operator policy. Also, per operator policy, emergency calls may be granted higher-priority QoS than other, non-emergency calls.

The QoS in the Customer Premises LAN network is out of scope of BSS. However, if differentiated service is used based on DSCP in the Customer Premises LAN network, there may be a need to coordinate DSCP values between the PacketCable access network.

The UE MUST comply with Differentiated Services Code Point (DSCP) marking requirements defined in [RSTF]. In summary, the upstream Internet Protocol (IP) packets are marked with a configurable DSCP according to whether

the IP packet content contains Non-Emergency Media, Emergency Media, Non-emergency Signaling, or Emergency Signaling. The Cable Modem Termination System (CMTS) is responsible for policing the DSCP value for upstream IP packets. It is assumed that any routers or other equipment between the UE and the Cable Modem (CM) will not alter the DSCP value set by the UE.

## 7 BUSINESS SIP SERVICES (BSS) FEATURE REQUIREMENTS

### 7.1 Caller ID

Caller ID features govern the delivery (or blocking) of the caller's number and name to the called party. The called party may permit (or disallow) the display of the caller's number and name; and the calling party may prohibit (or permit) the delivery of his number and name to the called party. In the case of Anonymous Call Rejection (ACR), the called party can automatically reject calls from parties that do not supply their identity to the called party.

The concept of 'Presentation Status' is fundamental to Caller ID services. A UE or the network is aware of the 'Presentation Status' for a particular call, the value of which can be either 'public' (identity can be displayed) or 'anonymous' (identity is to be withheld).

#### 7.1.1 Calling Name and Number Delivery

##### 7.1.1.1 Feature Execution

###### 7.1.1.1.1 UE

An originating UE in an initial request message SHOULD populate the From header with its Public Identity unless making use of the Extension Dialing capabilities defined in Section 7.9.3, in which case the requirements defined therein apply. An originating UE MAY also include in an initial request message a hint to the network of its preferred display identity by inclusion of a P-Preferred-Identity header.

A terminating UE displays the calling number if, and only if, the Calling Number (CND) feature is activated, and displays the calling name if, and only if, the Calling Name (CNAMD) feature is activated. The following steps specify how the calling number and name is displayed.

The identity to be displayed by the UE is retrieved either from the P-Asserted-Identity header (in the case where public identities are to be displayed) or from the From header (in the case where private identities are to be displayed). The decision on which header to use by the UE is based on configuration (either local to the UE or from the network).

For an analog UE, the UE MUST display the Caller ID Display information in accordance with Telcordia [GR 30] and [RSTF]. The date and time of the call is obtained from the UE clock.

For a non-analog UE, the UE MAY display the received Caller ID Display information in an implementation dependent manner. However, the UE SHOULD display at least the date/time of the incoming call, the name, and, if present, the telephone number of the caller.

###### 7.1.1.1.2 BSS AS

If the Calling Name (CNAMD) and Number (CND) Display Feature is active for a subscriber, then terminating call attempts to that subscriber where the call originator is requesting Caller ID suppression via inclusion of a Privacy header are routed to a BSS AS. This is so that the BSS AS can ensure appropriate header population to ensure anonymity, if for any reason the originator's network did not do so.

If the Calling Name Display feature is absent or inactive for a subscriber, a BSS AS can be invoked for terminating requests to that subscriber. This is specifically for the case where no privacy is indicated in the INVITE request, and the network operator wishes to ensure that the network itself removes calling party information to avoid inadvertent display at the UE. In this case, the BSS AS MAY insert the token "id" into an existing Privacy header or insert a new Privacy header containing the token "id".

For calls placed to a public identity that has subscribed to Calling Name and Number Display, the called party's network will examine the Privacy header in the incoming INVITE and forward or strip the P-Asserted-Identity header(s) to the UE according to the rules provided by [PKT 24.229] that govern transmission of identity information to an un-trusted domain/entity (the UE).

## 7.1.2 Caller ID Per-Line Blocking

### 7.1.2.1 Feature Execution

#### 7.1.2.1.1 UE

A UE that is aware of the default permanent presentation status applies the following rules when originating a call.

- If the permanent presentation status is "public":

The UE SHOULD insert a P-Preferred-Identity header containing the selected Public User Identity for the line. If there is more than one Public User Identity for the line, the UE SHOULD use the one in telephone number format.

The UE MUST NOT include a Privacy header containing a value of "id".

The UE SHOULD include the chosen Public User Identity in the From header.
- If the permanent presentation status is "anonymous":

The UE MAY insert a P-Preferred-Identity header containing the Public User Identity for the subscriber. If there is more than one Public User Identity for the line, the UE SHOULD use the one in telephone number format.

The UE SHOULD include a Privacy header containing a value of "id".

The UE SHOULD include the URI <sip:anonymous@anonymous.invalid> in the From header.

The UE SHOULD include the value "anonymous" as the display name in the From header.

If the UE fails to indicate a preferred identity for the call, the core network will assert an identity making use of the default identity for the subscriber as provided during registration.

#### 7.1.2.1.2 BSS AS

An originating BSS AS is triggered for all calls in order to enforce anonymity if the UE itself is not so capable. The actions performed by the BSS AS are as follows:

1. The BSS AS verifies the INVITE header field population based on its knowledge of the permanent presentation status of the UE assuming no per call feature has been invoked.
2. If the presentation status is "anonymous", and no Privacy header is present that is populated with a value of "id", then the BSS AS MUST include a Privacy header with a value of "id" in the INVITE.
3. When the presentation status is "anonymous" the BSS AS MUST apply the procedures defined within [RFC 3323] for URI anonymity to the URI in the From header.

### 7.1.2.2 Feature Data

For UEs that support configuration of the Permanent Presentation Status, the feature data defined in [RSTF] applies; otherwise no additional feature data is required in the UE for this feature.

## 7.1.3 Caller ID Per-Call Blocking (CIDS-Suppression)

### 7.1.3.1 Feature Execution

#### 7.1.3.1.1 UE

The user initiates CIDS-S for example by dialing the appropriate feature code (e.g., '\*67' + <destination number>). The UE, irrespective of the user interface provided, MUST construct a SIP INVITE (Section 6.4.1) including the defined feature code for CIDS-S and the target destination number.

#### 7.1.3.1.2 BSS AS

Reception in the originating network of an INVITE with a RequestURI containing the Vertical Service Code (VSC) defined for CIDS-S triggers the insertion of a BSS AS. The BSS AS acts on the presence of the VSC for CIDS-S and modifies the INVITE so that it is populated in an equivalent manner to the case where the Permanent Presentation Status is 'anonymous'.

- The BSS AS MUST include a Privacy header containing a value of "id".
- The BSS AS MUST include the URI <sip:anonymous@anonymous.invalid> in the From header.
- The BSS AS MUST include the value "anonymous" as the display name in the From header.
- The BSS AS MUST remove the VSC from the RequestURI before proxying the INVITE on.

#### **7.1.4 Caller ID Per-Call Delivery (CIDS-Delivery)**

##### **7.1.4.1 Feature Execution**

###### **7.1.4.1.1 UE**

The user initiates CIDS-D, for example, by dialing the appropriate feature code (e.g., '\*67' + <destination number>). The UE, irrespective of the user interface provided, MUST construct a SIP INVITE (Section 6.4.1) including the defined feature code for CIDS-D and the target destination number.

###### **7.1.4.1.2 BSS AS**

Reception in the originating network of an INVITE, with a RequestURI containing the VSC defined for CIDS-D triggers the insertion of a BSS AS. The BSS AS acts on the presence of the VSC for CIDS-D and modifies the INVITE so that it is populated in an equivalent manner to the case where the Permanent Presentation Status is 'public'.

- The BSS AS MUST include the selected Public User Identity for the subscriber in the From header.
- The BSS AS MUST include the calling name of the selected Public User Identity for the subscriber as the display name in the From header.

#### **7.1.5 Caller ID with Call Waiting (CIDCW)**

CIDCW is not a separate feature. It makes use of the Calling Name and Number Delivery service already specified.

#### **7.1.6 Anonymous Call Rejection**

##### **7.1.6.1 Feature Activation and Deactivation**

The user activates or deactivates Anonymous Call Rejection (ACR), for example, by dialing the appropriate feature code (e.g., '\*77' or '\*87'). The UE, irrespective of the user interface provided, MUST construct a SIP INVITE (Section 6.4.1) including the defined feature code for ACR activation or deactivation.

On successful activation or deactivation of the feature, the BSS AS MUST provide a confirmation tone or announcement to the subscriber. If an error occurs in the activation or deactivation of ACR, the BSS AS MUST provide an error tone or appropriate announcement.

##### **7.1.6.2 Feature Execution**

###### **7.1.6.2.1 UE**

If the originating UE receives a 433 final response as defined by [RFC 5079] containing a Warning header, then the UE, if display capable, SHOULD display the 'warn text' from the Warning header to the subscriber.

###### **7.1.6.2.2 BSS AS**

ACR logic is provided by the BSS AS providing terminating services to the UE. The actions performed by the BSS AS are as follows:

1. The BSS AS examines the contents of the Privacy header received in the INVITE.
2. If the Privacy header contains one of "id", "user", or "header", and the calling party is not a special case identity with ACR override, then the BSS AS marks the call as having a restricted identity. Special case identities are those associated with Emergency Services and Operator Services Personnel.
3. For calls identified as having a restricted identity, the BSS MUST perform the following actions when the terminating subscriber has the ACR service:

- Provide an appropriate audible indication to the originator that the call is being rejected due to the application of ACR.
  - Reject the INVITE by sending a 4xx class final response (433 Anonymity Disallowed as defined by reference [RFC 5079] is recommended).
4. If the originating identity is restricted, the BSS AS SHOULD include a Warning header in the final response with a "warn code" of 399 and "warn text" as determined by the service provider.

## 7.2 Call Forwarding

Call Forwarding features divert a call from its original target to a new, revised target, based upon rules associated with the called party. The conditions for forwarding a call can be situational, as in the case of Call Forwarding on Busy Line (CFBL) or Call Forwarding on Don't Answer (CFDA), or the call forwarding can be unconditional, as in the case of Call Forwarding Variable (CFV). Furthermore, call forwarding based on UE reachability (i.e., unregistered UE), or based on network availability (e.g., service maintenance, network outage) is specified. The loop detection requirements described in Section 6.3.1 apply to all Call Forwarding features.

### 7.2.1 Call Forwarding General

For all flavors of Call Forwarding, the BSS AS MUST provide forwarding loop detection and limitation of the number of call forwarding attempts as defined in Section 6.3.1.

For all flavors of Call Forwarding when the BSS AS re-targets the INVITE as part of the execution of the Call Forwarding logic, the BSS AS MUST insert a history-info header in accordance with Section 6.3.1.

### 7.2.2 Call Forwarding Variable (CFV)

#### 7.2.2.1 Feature Activation and Deactivation

The user activates or deactivates CFV, for example, by dialing the appropriate feature code (e.g., '\*73'). The UE, irrespective of the user interface provided, constructs a SIP INVITE (Section 6.4.1) including the defined feature code for CFV activation or deactivation.

The forward-to address is either sent by the UE at feature activation, or is pre-configured by the BSS service provider. If the CFV forward-to number is provided by the subscriber, the BSS AS removes the number from its subscriber data on successful deactivation of CFV. If the forward-to number is provided by the service provider, and CFV is marked inactive, the BSS AS does not erase the forward-to number.

The BSS AS MAY support making a verification call to the forward-to number as part of activation of Call Forwarding Variable. If supported and enabled, the BSS AS MUST execute a verification call, as specified in [RSTF].

Upon receipt of an INVITE with the CFV de-activation code, the BSS AS responds with a 200 OK. When the BSS AS receives the ACK from the UE, it plays a confirmation tone to the user regardless of whether CFV is active or not.

For the case of a UE supporting user notification of CFV as defined by [RSTF], the de-activation status of the UE will be provided by SIP signaling as described therein.

#### 7.2.2.2 Feature Execution

##### 7.2.2.2.1 UE

If the UE supports the dynamic service information techniques defined by [RSTF], then the status of the CFV service will be provided via SIP signaling as defined within [RSTF]. If the special conditions dial-tone is enabled for subscribers with the CFV feature activated, then each time a subscriber with CFV activated goes off hook, the UE MUST play the special conditions dial-tone as a reminder that CFV is active. Additionally, the UE on reception of a SIP NOTIFY as specified in [RSTF] MUST trigger a ringsplash when a call is forwarded.

##### 7.2.2.2.2 BSS AS

Upon receipt of an INVITE destined to a UE for which CFV is active, the BSS AS performs the following sequence of actions.

1. The BSS AS determines whether the call can be forwarded or not (operator services calls and emergency services calls are not forwarded).
2. If the call can be forwarded, the BSS AS MUST re-write the request-URI with the stored forward-to address and then proxy the INVITE on.
3. If the UE and BSS AS support the dynamic service information techniques defined by [RSTF], then the BSS AS on completion of the forwarding action MUST generate a SIP NOTIFY as specified in [RSTF].

### **7.2.2.3 Feature Data**

For UEs that support dynamic service information techniques, the feature data defined in [RSTF] applies; otherwise no feature data is required in the UE for this feature.

## **7.2.3 Call Forwarding Don't Answer (CFDA)**

### **7.2.3.1 Feature Execution**

#### **7.2.3.1.1 BSS AS**

For calls placed to a public identity that is subscribed to CFDA, the INVITE is proxied to a BSS AS. Upon receipt of the initial INVITE, the BSS AS performs the following actions:

1. The BSS AS forwards the INVITE to the target UE.
2. In order to support CFDA, the BSS AS provides a timer that serves as a 'no answer timeout' for the current call in progress. Thus upon receipt of a 180 Ringing response to the INVITE, the BSS AS starts the no answer timer unless resource reservation is in progress and this reservation is not complete. If resource reservation is in progress, then the BSS AS does not start the no answer timer until it proxies an updated SDP from the calling party showing that the resources are now reserved.
3. If the no answer timer expires before a 200 OK to the INVITE is received, the BSS AS MUST send a CANCEL to the target UE, and determine whether this call can be forwarded (for example, operator services calls and emergency services calls are not forwarded).
4. If the call can be forwarded, the BSS AS MUST re-write the request-URI with the provisioned forward-to address and then proxy the INVITE on.
5. If the BSS AS fails to receive any response to the INVITE from the target UE within the SIP transaction timeout, the BSS AS determines whether this call can be forwarded (for example, operator services calls and emergency services calls are not forwarded).
6. If the call can be forwarded, the BSS AS MUST re-write the request-URI with the provisioned forward-to address and proxy the INVITE on.

## **7.2.4 Call Forwarding on Busy Line (CFBL)**

### **7.2.4.1 Feature Execution**

#### **7.2.4.1.1 BSS AS**

For calls placed to a public identity that is subscribed to CFBL, the INVITE is proxied to a BSS AS. Upon receipt of the initial INVITE, the BSS AS performs the following actions:

1. The BSS AS forwards the INVITE to the target UE.
2. If the BSS AS receives a 486 BUSY or 600 BUSY EVERYWHERE in response to the INVITE, the BSS AS determines whether the call can be forwarded by checking the feature availability status for the target UE and for the presence of a forward-to-address.
3. If the BSS AS determines the call is eligible for forwarding, the BSS AS MUST replace the request URI in the original INVITE with the forward-to address, and forward the INVITE to the new target.
4. If the BSS AS determines that the call cannot be forwarded, the BSS AS MUST return the error response (either 486 or 600) to the requesting UE.

5. If the BSS AS does not receive a response to the forwarded INVITE, and there is no network failure indication, the BSS AS MUST NOT invoke the CFBL procedures and interpret this as a Call Forward Don't Answer (CFDA) condition.
6. For all other responses to the forward INVITE, the BSS AS MUST proxy the response back to the requesting UE.

## **7.2.5 Selective Call Forwarding (SCF)**

### **7.2.5.1 Feature Activation and Deactivation**

The user activates or deactivates Selective Call Forwarding (SCF), for example, by dialing the appropriate feature code (e.g., '\*63' or '\*83'). The UE, irrespective of the user interface provided, MUST construct a SIP INVITE (Section 6.4.1) including the defined feature code for SCF activation or deactivation, thus establishing a SIP session between the UE and the BSS AS. The BSS AS MAY, in turn, connect the user to an Interactive Voice Responder (IVR) system for SCF programming and activation and deactivation.

As part of the SCF programming operation, the BSS AS MAY provide the user with a Screening List Editing (SLE) feature, as described in Section 7.6.3, to program a list of callers (that is, their public user IDs) who are subject to SCF treatment when the SCF feature is in effect.

If the BSS UE and BSS AS support the dynamic service information techniques defined by [RSTF], then the BSS AS MUST provide the status of the SCF service to the BSS UE via SIP signaling as defined within [RSTF].

Once the remote address is specified, the BSS AS MUST store the forward-to address in such a manner that it remains persistent even in the case of power loss in the UE or the BSS AS. Similarly, the BSS AS MUST store the screening list for SCF in such a manner that it remains persistent even in the case of power loss in the UE or BSS AS.

### **7.2.5.2 Feature Execution**

#### **7.2.5.2.1 UE**

If the UE supports the dynamic service information techniques defined by [RSTF], then the UE on reception of a SIP NOTIFY as specified in [RSTF], MUST trigger a ringsplash when a call is forwarded.

#### **7.2.5.2.2 BSS AS**

Upon receipt of an INVITE, the BSS AS decides if the INVITE needs to be presented to the called UE based on the current status of the SCF feature and whether the calling party is present in the Screen List. The current feature status is determined by the feature provisioning information and the activation/deactivation status previously set by the user (via the telephony user interface or the web portal).

If the SCF feature is not active, the BSS AS MUST forward the INVITE to the called party.

If the SCF feature is active, the BSS AS performs the following actions:

1. The BSS AS tries to match the calling party's public user ID with an entry in the Screen List.
2. If a match is established, the BSS AS MUST re-write the request URI of the INVITE to that of the forward-to address and then proxy the INVITE on. An address can exist on an SCF list as a Tel URI in an extension format (when applicable), in its 7/10 digit format, in both formats (that is, two entries on the list) or as a SIP URI. When the address of an incoming call is compared to the subscriber's SCF list, a match should be found if that address exists on the list in any format, regardless of the format of the incoming address.
3. If the UE and BSS AS support the dynamic service information techniques defined by [RSTF], then the BSS AS, on completion of the selective forwarding action, MUST generate a SIP NOTIFY as specified in [RSTF].
4. If the SCF feature is active and a match is not found, the BSS AS MUST forward the INVITE to the called party.

### **7.2.5.3 Feature Data**

For UEs that support dynamic service information techniques, the feature data defined in [RSTF] applies; otherwise no feature data is required in the UE for this feature.

## 7.2.6 Remote Activation of Call Forwarding

### 7.2.6.1 Feature Activation and Deactivation

Feature activation and deactivation for Remote Activation of Call Forwarding (RACF) is as defined in [RSTF].

### 7.2.6.2 Feature Execution

RACF is solely an activation and deactivation feature. There is no call processing impact for RACF.

## 7.2.7 Call Forwarding to Voice Mail

Call forwarding to voice mail is achieved by setting the forward-to address of CFDA, CFBL or CFNA to the address of the voice mail system. Some network operators may wish to allow the voice mail system to know why the call was forwarded (busy versus no answer, for example). The BSS AS MAY insert reason information in the INVITE response per [RFC 4458].

## 7.2.8 Call Forwarding Endpoint/Network Not Available (CFNA)

### 7.2.8.1 Feature Execution

#### 7.2.8.1.1 BSS AS

The BSS AS providing CFNA is required to be aware of the registration state of the subscriber for whom the CFNA service is active. This can be achieved by one of the following two methods:

1. The BSS AS subscribes to the 'reg' event package (see [RFC 3680]) of the UE, which itself is subscribed to the CFNA service, or
2. Creation of an iFC containing a Service Point Trigger for the subscriber, which triggers on a Session Case of terminating-unregistered and which also provides as the ServerName an AS URI that uniquely indicates to the BSS AS that the INVITE request is for an unregistered terminating call attempt.

For calls placed to a public identity that is subscribed to CFNA, the INVITE is proxied to a BSS AS. If the public identity is not registered, and the BSS AS determines that the call can be forwarded, the BSS AS MUST re-write the request-URI with the CFNA forward-to address and then proxy the INVITE on.

If the public identity is registered, then the BSS AS MUST send the INVITE towards the public identity. It is possible that network conditions may prevent the INVITE from being presented to the terminating party. If the BSS AS receives one of the following three SIP responses to the proxied INVITE – 408 Request timeout response, 503 Service unavailable, 500 Server internal error – and the BSS AS determines that the call can be forwarded, the BSS AS MUST rewrite the request-URI with the CFNA forward-to address and then proxy the INVITE on.

## 7.3 Call Blocking Features

Call Blocking features provide usage limitations (and hence billing limitations) on call originations and call terminations. Origination limitations may be against call type (such as International or Premium Rate), termination limitations may be against collect calls, or make use of white list or black list screening methods. For PacketCable, the option exists of applying these features to all UEs registered to the public user identity being billed, or to the individual UEs on a SIP device URI basis.

### 7.3.1 Outbound Call Blocking

#### 7.3.1.1 Feature Execution

##### 7.3.1.1.1 BSS AS

As this feature is entirely provided by a BSS AS, there are no additional SIP interface requirements to be defined.

#### 7.3.1.2 Call Flows

Refer to the sections on Basic Call (Section 6.4.1) and Early Media (Section 6.4.2) for the typical call flows required to implement the Outbound Call Blocking feature.

## 7.3.2 Collect Call Blocking

### 7.3.2.1 Feature Execution

As this feature is entirely provided by a BSS AS interacting with LIDB (Line Identification Database), there are no additional SIP interface requirements to be defined.

## 7.3.3 Selective Call Acceptance (White List)

### 7.3.3.1 Feature Execution

#### 7.3.3.1.1 BSS AS

As this feature is entirely provided by a BSS AS, there are no additional SIP interface requirements to be defined.

### 7.3.3.2 Call Flows

Refer to the sections on Basic Call (Section 6.4.1) and Early Media (Section 6.4.2) for the typical call flows required to implement the Selective Call Acceptance feature.

## 7.3.4 Selective Call Rejection (Black List)

### 7.3.4.1 Feature Execution

As this feature is entirely provided by a BSS AS, there are no additional SIP interface requirements to be defined.

### 7.3.4.2 Call Flows

Refer to the sections on Basic Call (Section 6.4.1) and Early Media (Section 6.4.2) for the typical call flows required to implement the Selective Call Rejection feature.

## 7.4 Multi-Party Features

### 7.4.1 Call Waiting

The Call Waiting (CW) feature provides the subscriber with the ability to detect an incoming call while in an existing call, and to answer that new call while at the same time putting the existing call on hold. There are two parts to this feature: activation/deactivation (disabling and enabling on a percall basis), and execution.

#### 7.4.1.1 Feature Activation and Deactivation

For RST-capable UEs, feature activation and deactivation is carried out as defined in [RSTF].

For non-RST UEs, the ability for call waiting to be disabled for incoming calls may be achieved on a per call basis. This is done by the user either dialing a pre-defined VSC as part of the dial-string when making an outgoing call or indicating to the UE via device specific means that Call Waiting is to be cancelled for this call attempt. In either case, the UE recognizes the VSC (and does not present it as part of the dial string presented to the network) or the alternative user stimulus and locally sets an indication on the device to reject incoming call attempts when currently engaged in an active call.

#### 7.4.1.2 Feature Execution

##### 7.4.1.2.1 UE

Service execution consists of call termination (similar to basic call termination) while the UE is in an established call. For UEs that cannot hold the currently active call (i.e., the current call is a three-way call and resource limitations prevent holding of the 3-way bridge), then that UE MUST reject the incoming INVITE with a 486 Busy Here final response. Additionally, if call waiting had been disabled for the currently active call, the UE MUST send an appropriate 4XX final response (486 Busy Here is recommended) to new incoming call attempts for the duration of the call for which call waiting has been disabled.

If the currently active call is an Emergency call as defined in Section 7.8 of this specification, then the UE MUST reject the incoming INVITE with a 486 Busy Here final response and not put the Emergency call on hold.

If there is an active call that can be held when another INVITE is received by the UE and call waiting has not been disabled, the UE MUST play a call waiting tone or other indication appropriate to the device type to the subscriber. The indication provided SHOULD match the agreed cadence for the alert-info header if such a header is present in

the INVITE of the incoming call. Otherwise, the indication SHOULD be as specified in [GR 571]. The terminating UE MUST provide the indication so that only the terminating subscriber hears or is otherwise aware of the call waiting indication.

For UEs that are capable of hook-switch flash, if the UE detects a flash, it MUST hold the existing call's media as defined in [RSTF]. Other device types are expected to provide device-appropriate mechanisms to allow the user to switch to the call that is waiting while holding the existing call's media as defined in [RSTF]. For all UEs, irrespective of hook-switch flash capabilities, the UE MUST accept the new call from the network once the re-INVITE for the old call completes, and stop providing the call waiting indication. The UE MUST reject the incoming call with an appropriate 4XX final response (486 Busy Here is recommended) if the hold attempt of the existing active call fails.

If the UE does not detect an attempt to switch to the call in wait, it MUST stop playing the call waiting indication; for RST-conformant UEs, this is after applying the second iteration of the tone to the handset for the duration and repetition interval, as defined in [GR 571]. The UE MUST then send an appropriate 4XX final response (486 Busy Here is recommended) to the waiting call.

## **7.4.2 Call Hold**

During an active call, the Call Hold feature allows the user to place the call on hold, without ending the call. The call is kept on hold while the user may switch to perform other tasks, e.g., making a call to another destination.

### **7.4.2.1 Feature Activation and Deactivation**

The user interface to trigger Call Hold depends on UE types. For the case of a UE with an analog interface, the user presses hook flash, hears a recall dial tone, then dials the Call Hold VSC. The UE recognizes the Call Hold VSC as defined by its digit map, and triggers the Call Hold action. For the case of a UE without an analog interface, the user interface may be different, for example, having a Hold button.

It should be noted that there is only one VSC, for the case of UE with analog interface, to activate or deactivate Call Hold, as it is the state in which the UE is that determines whether it is for activation, or for deactivation.

### **7.4.2.2 Feature Execution**

#### **7.4.2.2.1 UE**

If the user activates Call Hold while on a currently active call, the UE MUST hold the media for the existing call using the mechanisms defined in [RSTF]. The UE MAY play comfort noise or silence insertion packets to and from the user while the media is being held.

If the UE receives a BYE on the held call's dialog while the user is making another call attempt, the UE MUST terminate the held call by sending a 200 OK for the BYE. The UE MUST then allow the second call attempt to continue.

At any given time, a UE with an analog interface MUST NOT allow more than one call to be held via the mechanism described in Section 7.4.2.1. There is no such limitation on UEs not having an analog interface.

## **7.4.3 Music on Hold**

The Music on Hold feature uses pre-recorded audio to fill the silence that would otherwise be heard by callers placed on hold. Although music is commonly used, the audio stream could provide information considered of value to the caller, such as business hours, products, services, and promotions.

### **7.4.3.1 Feature Execution**

#### **7.4.3.1.1 UE**

UE actions to both hold and retrieve media are defined in Section 7.4.2.

#### **7.4.3.1.2 BSS AS**

A BSS AS providing Music On Hold, on reception of an INVITE containing hold SDP as per [RFC 3264], MUST modify the SDP to the SDP associated with the BSS AS media server, and forward that re-INVITE towards the target UE. Once the target UE successfully answers this INVITE and the media path is established between the BSS AS media server and the held UE, the BSS AS MUST play the selected media toward the held UE.

Upon reception of a re-INVITE populated with a media resume SDP as defined in [RFC 3264], the BSS AS MUST stop playing the music and forward that re-INVITE towards the held UE.

#### **7.4.4 Consultation Hold**

The Consultation Hold feature enables a user to put the caller on hold and make a consultation call to another party.

##### **7.4.4.1 Feature Execution**

A UE having the consultation hold capability performs a consultation hold by first putting the current call on hold (see Section 7.4.2), and initiating a call towards a third party. Once that third party call is terminated, the UE resume its call towards the held party by sending a re-INVITE with the appropriate SDP.

#### **7.4.5 Call Transfer**

Call Transfer is the transfer of one caller (the transferee) to another party (the transfer-to party), in which the transfer is initiated by the originator of the second call (the transferor). As described in [GR 579], there are two common varieties of call transfer - consultative and blind. Consultative transfer is specified by [GR 579]. This specification defines blind transfer in terms of the state of the second call: if the call is unanswered before completion of the transfer sequence, the transfer is considered blind.

##### **7.4.5.1 Feature Execution**

###### **7.4.5.1.1 UE**

###### **7.4.5.1.1.1 Transferor**

The following procedures apply to UEs that are not RST capable.

Upon detection of a hook-switch flash or other feature initiating action on the existing call with the transferee the UE SHOULD send a re-INVITE to hold the remote party. The UE then enables the collection of digits for the second call origination.

Upon detection of a valid digit string, the UE initiates the second call via an INVITE. This call is handled by the UE and network the same way as any basic call origination.

When the transferor hangs up or otherwise initiates the completion of the transfer, the transferor's UE MUST send a REFER to the transferee within the existing dialog, having a Refer-To header containing (if supported ) a nested Replaces header with the SIP dialog information of the dialog between the transferor and the transfer-to party.

The transferor's UE SHOULD wait for NOTIFY message(s) from the final recipient of the REFER indicating the transfer result.

If the transferor hangs up before the transfer-to party picks up, the transferor's UE MUST send a CANCEL to the transfer-to party and a BYE to the transferee upon one of the following conditions:

- Receipt of a NOTIFY message from the final recipient of the REFER indicating successful initiation of the transfer.
- Expiration of the Notify-timeout (as specified in [RSTF]) before receiving a NOTIFY from the final recipient of the REFER.

If the transferor hangs up after the transfer-to party has picked up, the transferor's UE MUST send a BYE to the transferee and the transfer-to party upon one of the following conditions:

- Receiving a NOTIFY message from the final recipient of the REFER indicating successful initiation of the transfer.
- Expiration of the Notify-timeout (as specified in [RSTF]) before receiving a NOTIFY from the final recipient of the REFER.

###### **7.4.5.1.1.2 Transferee**

When the transferee's UE receives a REFER, it performs the following:

- Send an INVITE using the Refer-To header in the REFER for the request URI.

- Notify the transferor of call status with a NOTIFY.

#### 7.4.5.1.1.3 Transfer-to party

When the transfer-to party's UE receives an out-of-dialog INVITE, it performs the following:

- Match the content of the Replaces header (if supported and if received) in the out-of-dialog INVITE to the existing dialog with the transferor. Note: Use of the Replaces header on an early dialog between the transfer-to and transferee in the case of blind transfer diverges from the use specified in [RFC 3891]; however, as noted in 7.4.5.1.2.2, a BSS AS will only provide an INVITE with Replaces on an early dialog to a UE where the BSS AS has explicit knowledge of UE support of this behavior.
- Reject the INVITE with a 481 Call/Transaction Does Not Exist final response if the Replaces header does not match the existing dialog with the transferor.

#### 7.4.5.1.2 BSS AS

For BSS UEs that are not RST-capable, the BSS AS, acting as a B2BUA, needs to be in the call path for all requests for all calls where the subscriber has a call transfer capability.

For RST-capable UEs, the BSS AS will be invoked once the out-of-dialog REFER is received, subsequent processing of the REFER in this case is as defined in [RSTF].

When the BSS AS receives an in-dialog REFER from the transferor, the BSS AS first verifies if the transfer attempt is blind or consultative based on the known status of the dialog between the transferor and the transfer-to party.

##### 7.4.5.1.2.1 Consultative Transfer Actions

If the transfer attempt is consultative, the BSS AS performs the following when handling the in dialog REFER received from the transferor:

- The BSS AS SHOULD validate the subscriber's ability to transfer, and reject if invalid.
- The BSS AS SHOULD replace the Refer-to header content with its private Uniform Resource Locator (URL).
- The BSS AS SHOULD proxy the REFER to the destination indicated in the request URI.
- The BSS AS SHOULD add its record route entry to the REFER before proxying in order to receive subsequent NOTIFY messages from the recipient of the REFER.
- The BSS AS MUST proxy NOTIFY messages to the Serving – Call Session Control Function (S-CSCF).

The BSS AS for operational, configuration, or other reasons could choose not to proxy the REFER; in these cases the BSS AS acts as a B2BUA and uses re-INVITEs and other call leg manipulation techniques to transfer the media between Transferee and Transfer-To.

When the BSS AS receives an INVITE that matches a previously proxied REFER, the BSS AS determines if the transfer attempt is making use of the Replaces header (and the transfer-to supports Replaces) or not.

If a Replaces header was present as a nested header in the original Refer-To header and the BSS AS has determined by its own internal mechanisms that the transfer-to party also supports Replaces, then the BSS AS MUST perform the following:

- Replace the request URI in the INVITE with the original Refer-to contents, inserting the embedded Replaces header as a discrete header within the INVITE.
- Proxy the INVITE.

If no Replaces header was present as a nested header in the original Refer-To header, or a Replaces header was present but the BSS AS has determined by its own internal mechanisms that the transfer-to party does not support Replaces, then the BSS AS MUST make use of 3PCC techniques to manipulate the call legs; it is recommended that such techniques follow the guidance presented in [RFC 3725]. The following illustrates a potential approach that the BSS AS may take in applying these techniques:

- Optionally provide progress media to the transferee during the transfer attempt.

- Re-INVITE with held media the transfer-to party on the existing dialog between the transferor and the transfer-to parties.
- On completion of the hold attempt, re-INVITE the transfer-to party with the SDP from the INVITE received from the transferee.
- Act as a B2BUA and ensure completion of the offer-answer exchange between the transferee and the transfer-to parties.
- Release (using BYE) the call leg to the transferor.

When the BSS AS receives an INVITE that does not match a previously proxied REFER, the BSS AS processes it as per standard SIP procedures.

#### 7.4.5.1.2.2 Blind Transfer Actions

If the transfer attempt is blind, the BSS AS then performs the following when handling the in dialog REFER received from the transferor:

- The BSS AS SHOULD validate the subscriber's ability to transfer, and reject if invalid.
- The BSS AS SHOULD replace the Refer-to header content with its private URL.
- The BSS AS SHOULD proxy the REFER to the destination indicated in the request URI.
- The BSS AS SHOULD add its record route entry to the REFER before proxying in order to receive subsequent NOTIFY messages from the recipient of the REFER.
- The BSS AS MUST proxy NOTIFY messages to the S-CSCF.

For the case where the BSS AS for operational, configuration, or other reasons chooses not to proxy the REFER, then the BSS AS acts as a B2BUA and uses re-INVITES and other call leg manipulation techniques to transfer the media between Transferee and Transfer-To.

When the BSS AS receives an INVITE that matches a previously proxied REFER, the BSS AS determines if the transfer attempt is making use of the Replaces header (and the transfer-to supports Replaces).

If a Replaces header was present as a nested header in the original Refer-To header, and the BSS AS has determined by its own internal mechanisms that the transfer-to party also supports Replaces as applied to an early dialog, then the BSS AS MUST perform the following:

- Replace the request URI in the INVITE with the original Refer-to contents, inserting the embedded Replaces header as a discrete header within the INVITE.
- Proxy the INVITE.

If no Replaces header was present as a nested header in the original Refer-To header, or a Replaces header was present but the BSS AS has determined by its own internal mechanisms that the transfer-to party does not support Replaces or the reception of a Replaces header for an early dialog, then the BSS AS MUST make use of 3PCC techniques to manipulate the call legs; it is recommended that such techniques follow the guidance presented in [RFC 3725]. The BSS AS SHOULD also ensure that the Transfer-To party is provided with the identity of the Transferee for CallerID display purposes. The following illustrates a potential approach that the BSS AS may take in applying these techniques:

- Optionally provide progress media to the transferee during the transfer attempt.
- If the transfer-to party indicated in the Allow header that it supports the UPDATE method, send an UPDATE to the transfer-to party providing the transferee's identity. Additionally if an offer-answer exchange has already been completed between the transfer-to party and the transferor, re-negotiate the media within the UPDATE transaction by offering the SDP received from the transferee.
- On reception of a 200 OK from the transfer-to party, and if media was not re-negotiated in an UPDATE transaction; use 3PCC techniques to establish media between the transferee and the transfer-to parties.
- Release (using BYE) the call leg to the transferor.

When the BSS AS receives an INVITE that does not match a previously proxied REFER, the BSS AS processes it as per standard SIP procedures.

#### 7.4.5.1.2.3 Interworking with Out Of Dialog REFER

UEs that conform to [RSTF] make use of a REFER sent outside of a dialog to perform call transfer.

In order to provide interoperability with the [RSTF] defined procedures for call transfer, a BSS AS is inserted into the call by the core network on reception of an out-of-dialog REFER targeted at a subscriber that does not support the [RSTF] procedures (i.e., the subscriber has a Service Point Trigger with a Session Case of "Terminating-Registered"). From the REFER, the BSS AS identifies the associated dialog from the Target-Dialog header received in the REFER. The BSS AS MUST then implement one of the following options:

1. Proxy this REFER within the dialog identified in the Target-Dialog header after having first removed this header. If no dialog is found matching the Target-Dialog header, then the REFER is rejected as defined in [RFC 4538].
2. Act as a B2BUA and uses re-INVITES and other call leg manipulation techniques to transfer the media between Transferee and Transfer-To.

The transfer attempt from this point follows the procedures defined within this specification.

#### **7.4.5.2 Call Flows**

The following call flows are not normative, so if there is a discrepancy between the text requirements and these call flows, then the text requirements take precedence.

Figure 1 shows the call flow for a consult transfer where the Transfer-To party supports reception of the Replaces header in an INVITE and can act on it in accordance with applicable RFCs.

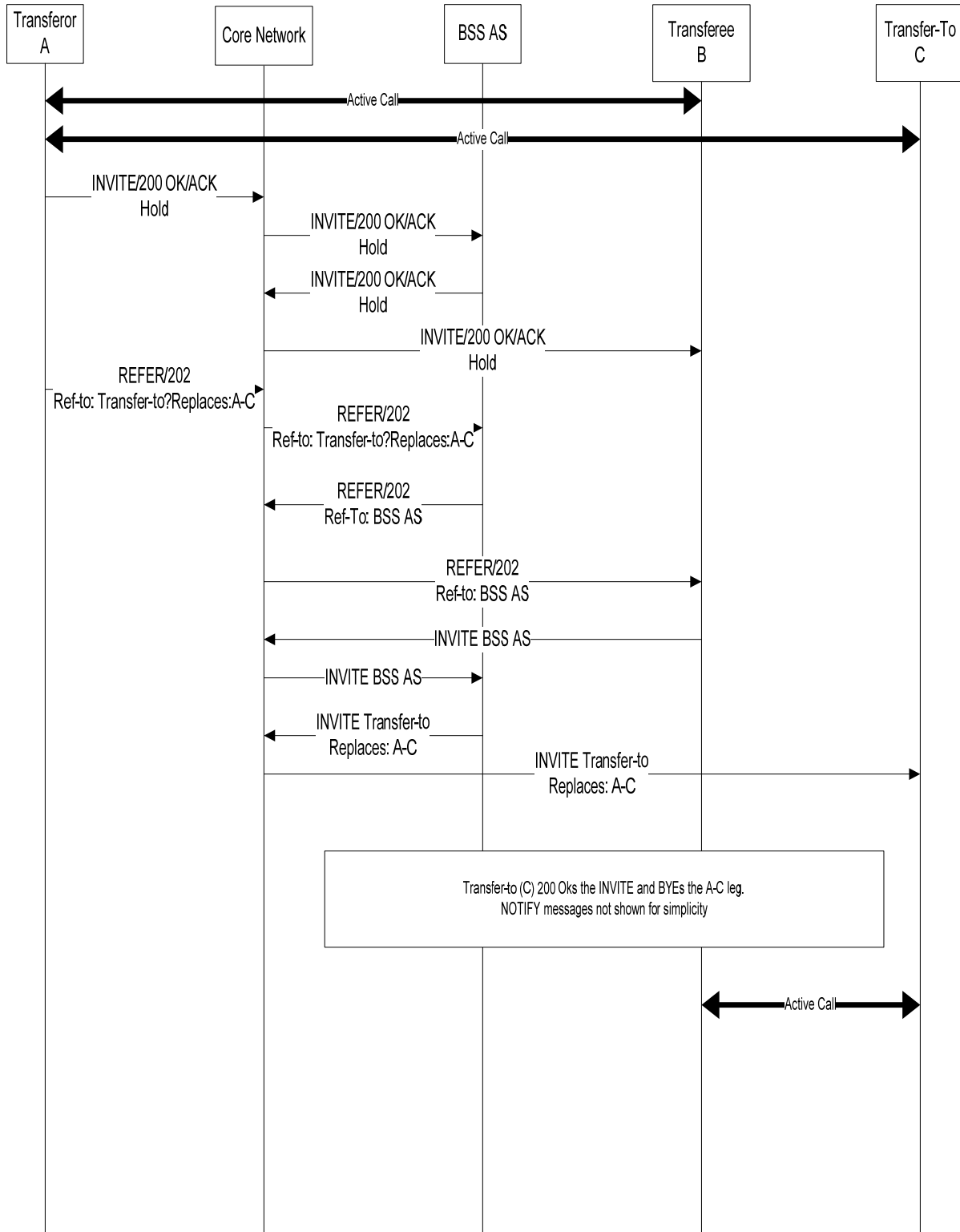

Figure 1 - Call Transfer; Consultative Transfer Using Replaces

Figure 2 shows the call flow for a consult transfer where the Transfer-To party does not support reception of the Replaces header in an INVITE and so the BSS invokes 3PCC procedures.

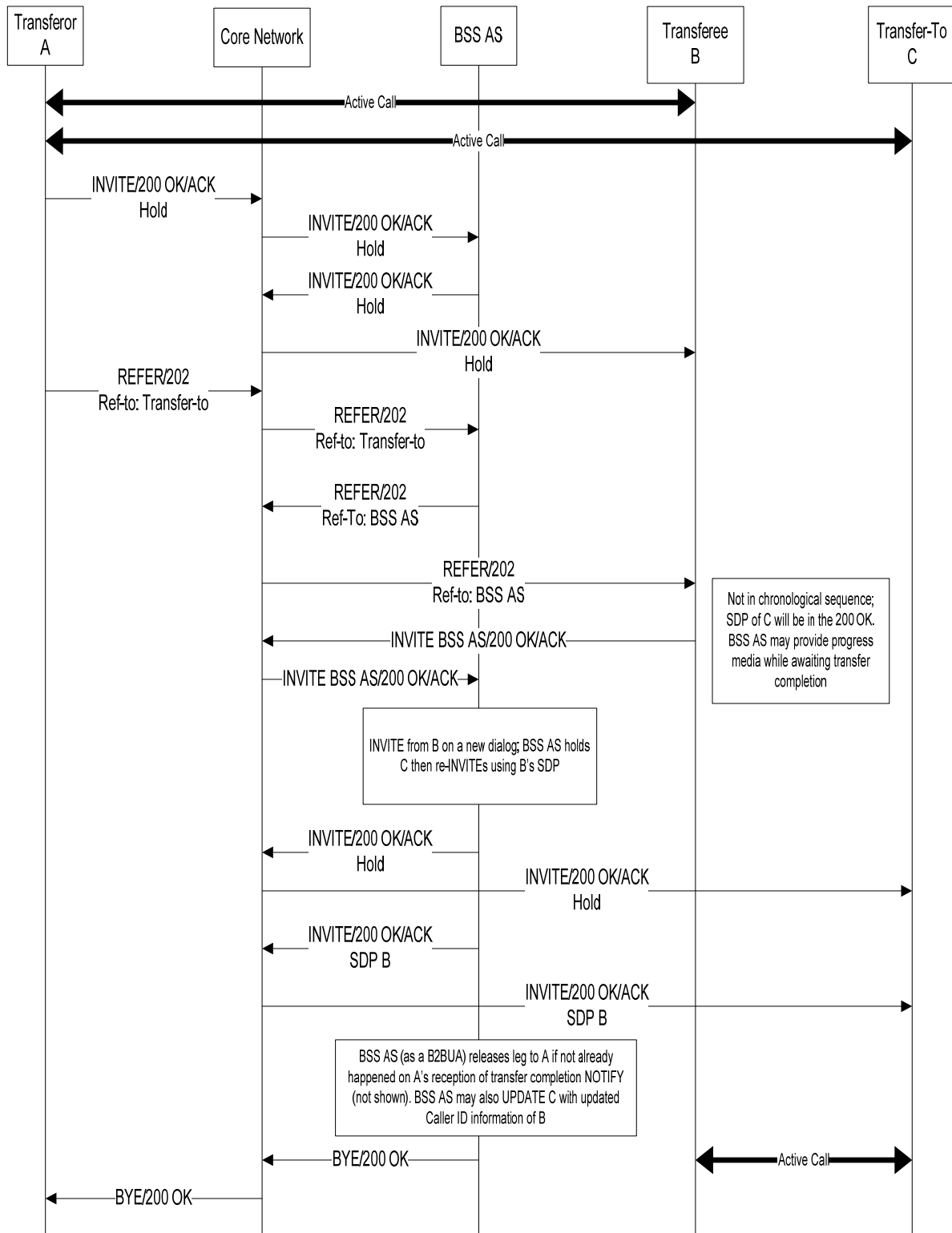

Figure 2 - Call Transfer; Consultative Transfer Using 3PCC

Figure 3 shows the call flow for a blind transfer where the Transfer-To party supports reception of the Replaces header for an Early-Dialog in an INVITE and can act on it in accordance with [RSTF].

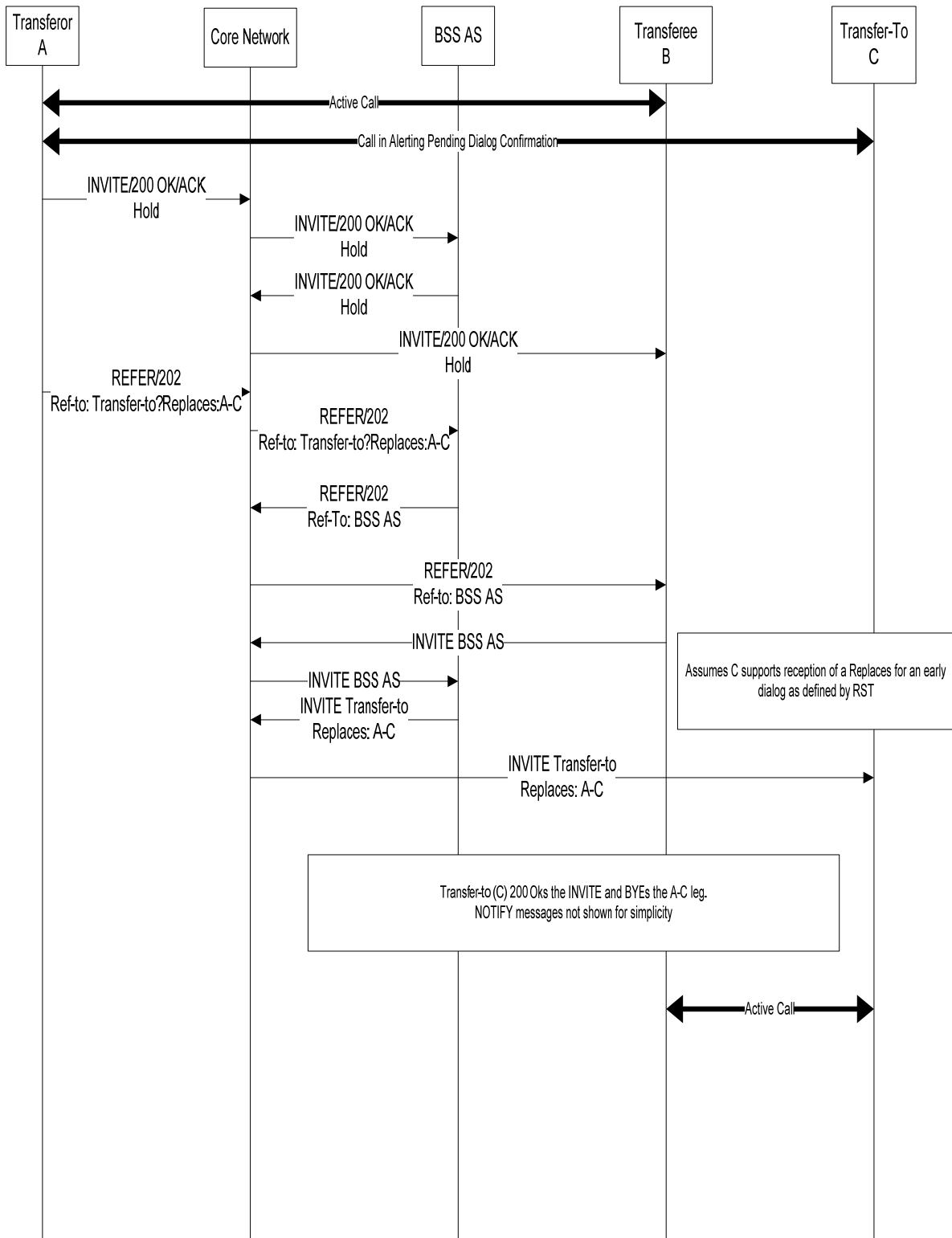

Figure 3 - Call Transfer; Blind Transfer Using Replaces

Figure 4 shows the call flow for a consult transfer where the Transfer-To party does not support reception of the Replaces header in an INVITE and so the BSS invokes 3PCC procedures including the use of UPDATE to provide the identity of the Transferee to the Transfer-To party.

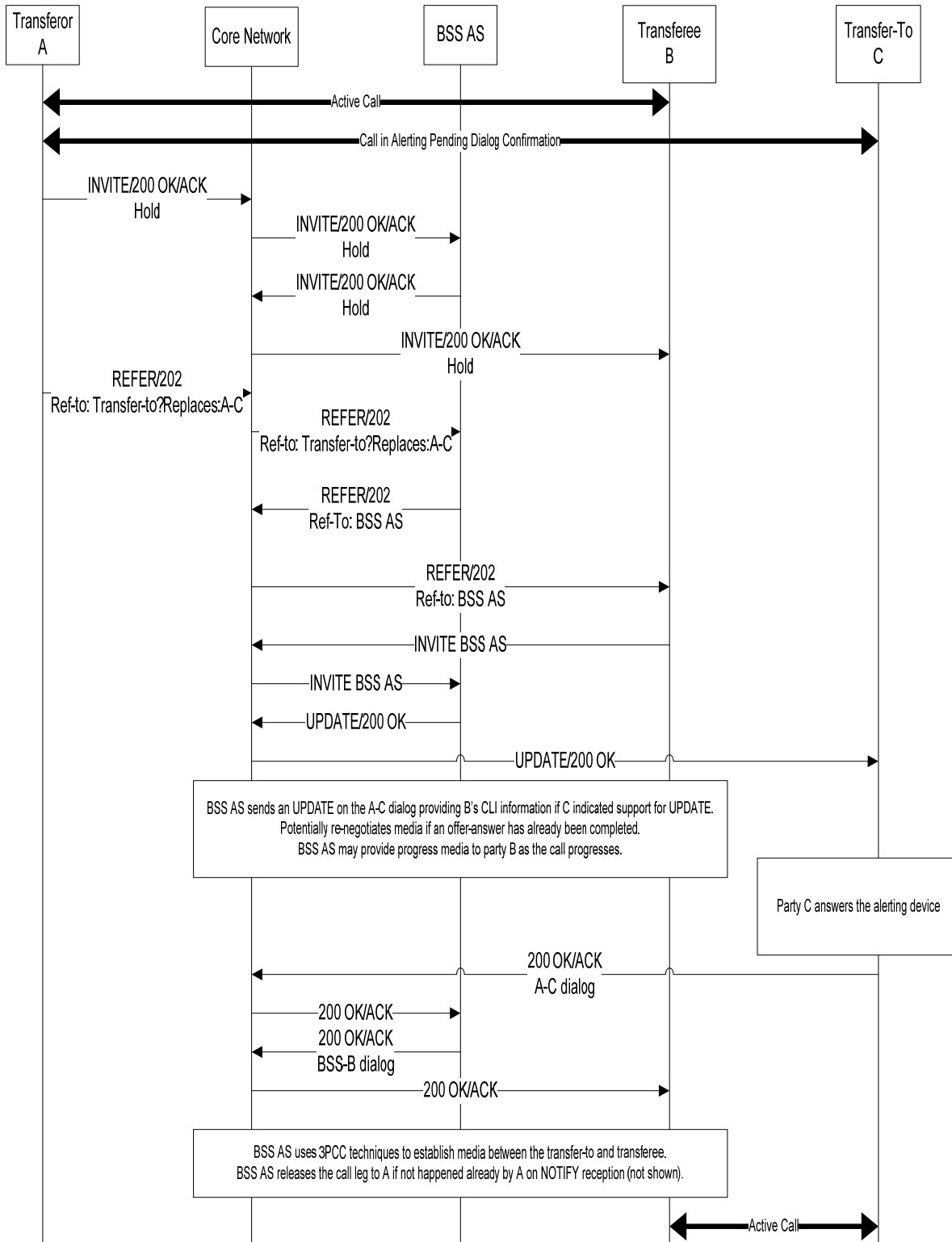

Figure 4 - Call Transfer; Consultative Transfer Using 3PCC and Identity Update

Figure 5 shows the call flow for the case where the BSS AS receives an Out of Dialog REFER from a UE or network that supports the [RSTF] implementation of call transfer.

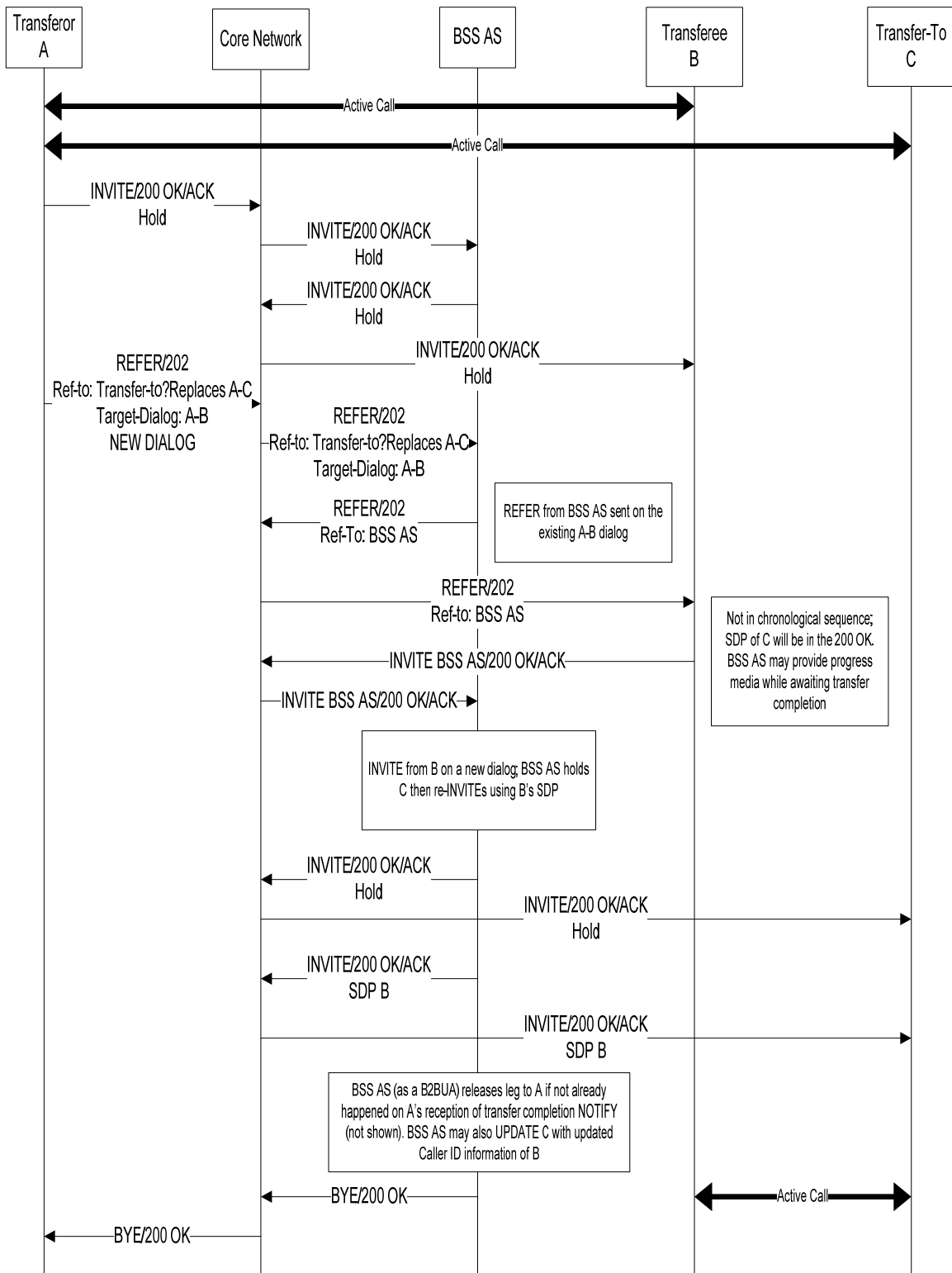

Figure 5 - Call Transfer; Interworking with Out of Dialog REFER

## 7.4.6 Three-Way Calling

Three-Way Calling (3WC) allows a subscriber to add a third party to an existing two-party active call without operator assistance. The subscriber initiating the 3WC is called the controller.

### 7.4.6.1 Feature Execution

RST capable UEs locally support a three party bridge and MUST adhere to the feature execution requirements as defined in [RSTF].

UEs that are not capable of locally supporting a three party bridge provide 3WC capabilities following the high-level procedure noted below:

1. By definition, before a UE can start a three-way call, the UE is assumed to be involved in a stable call. It does not matter which party originated the call.
2. Upon detection of an appropriate feature stimulus (e.g., hook flash), the UE may hold the original call media as defined within [RSTF]; the UE then provides an indication that destination digits for a second call leg are to be entered by the subscriber.
3. On receiving a dial string, the UE initiates the second call by sending an INVITE to the network.
4. If the second call attempt succeeds, the subscriber may speak to the third party privately.
5. Upon detection of an appropriate feature stimulus (e.g., hook flash), the UE joins the held call with the second call leg to form a Three-Way Call (3WC). Actions to create the 3WC depend on the UEs local bridging capabilities:
  - A UE with local bridging capabilities creates a conference by mixing the audio received on the two call legs with the audio received from the local party, and sends the mixed audio in the RTP streams sent to the two call legs.
  - A UE without local bridging capabilities follows the procedures defined in Section 7.4.7 as a result of this stimulus action to ensure the reservation of a conference bridge in the network and the transfer of all current call legs to that bridge.

### 7.4.6.2 Feature Data

No feature data is required in the UE for this feature.

The use of network-based facilities to achieve the service for UEs that do not support local bridging makes use of the procedures and Feature Data defined in Section 7.4.7.2.

## 7.4.7 Multi-Party Conference Calling

Multi-Party Conference Calling allows a subscriber to conference multiple call legs together making use of network-hosted resources up to a network-defined limit.

### 7.4.7.1 Feature Execution

#### 7.4.7.1.1 UE

The execution of the feature extends from the definition of the network hosted variant of the 3WC service defined in Section 7.4.6.1. It is recommended that the procedures of [TS 24.147] are followed by the controlling UE.

At a minimum, a UE that supports Multiparty Conference Calling first reserves a conference bridge in the network. To do so, the UE MUST send an INVITE with the RequestURI set to the pre-configured Conference Factory URI. On creation of the conference, the appropriate network resources respond with a 200 OK. The UE invoking the conference MUST use the Contact header received in the 200 OK as the discovered Conference URI that identifies the conference focus for subsequent actions. Additional recommended guidance on the use of a Conference URI is provided in [RFC 4579].

Once the conference has been created, the controlling UE then invites the other conference participants to the conference. The UE **MUST** make use of one of the following alternative methods:

- The controlling UE sends an in dialog REFER to each conference participant. The Refer-To header **MUST** be populated with the discovered Conference URI.
- The controlling UE sends an in-dialog REFER to the conference focus for each participant. The RequestURI of the REFER **MUST** be set to the discovered Conference URI. The Refer-To header **MUST** be populated with the URI (or Globally Routable User-Agent URI (GRUU) if discovered and supported) of the proposed conference participant. The Refer-To header **SHOULD** contain a nested Replaces header identifying the active dialog between the controlling party and the conference participant.

The non-controlling parties do not have to be conference bridge aware, they will simply receive standard SIP methods (REFER or INVITE), which result in their media being re-directed and re-negotiated with the conference focus.

#### 7.4.7.2 Feature Data

Table 3 summarizes the UE configuration items defined to support implementation of the Multi-Party Conferencing feature.

**Table 3 - Multi-Party Conferencing Feature Data**

Data	Type	UE Persistence	Scope	UE Provisioning
Conference Factory URI	String	Non-volatile	Per network	Mandatory Writable

#### 7.4.7.3 Call Flows

An informative set of representative flows may be found in [RFC 4579].

## 7.5 Call History Features

### 7.5.1 Automatic Recall (Last Call Return)

The Automatic Recall (AR) feature allows a UE to automatically return a call to the last calling address (the target address is the P-Asserted-ID of the caller) that sent an INVITE to this UE, whether the INVITE was answered by this UE or not. The AR feature should work even when the last call received at the UE withheld their Caller ID.

The feature as described in this specification, is implemented by the BSS AS and places minimal requirements on the UE; however, it does require that the BSS AS be in the call path for all UEs that may be subject to an AR request or the target of an AR request. Whenever a public identity is subscribed to the AR feature, all calls placed to the public identity are sent via the BSS AS. The AS records the public identity and privacy setting of the most recent terminating call.

Based upon operator policy and subject to UE capability, the AR procedures described in [RSTF] may be used instead of the procedures described in this section. Alternatively, a UE compliant with [RSTF] can use the procedures described in this section through changing the digit map so that matching against the AR activation VSC invokes the MAKE-CALL action passing into it all dialed digits rather than the AR-ACTIVATE action.

#### 7.5.1.1 Feature Activation and Deactivation

##### 7.5.1.1.1 UE

The subscriber activates the AR feature, for example, by dialing the AR activation VSC. The UE **MUST** send an INVITE with the Request URI containing the AR activation code.

The subscriber deactivates the AR feature, for example, by dialing the AR deactivation VSC. The UE **MUST** send an INVITE with the Request URI containing the AR deactivation code.

### 7.5.1.1.2 BSS AS

When the requestor's BSS AS receives an INVITE containing the AR activation VSC, it invokes the AR activation service logic. This will typically consist of the following steps:

- If the BSS AS is configured for two-stage activation, it plays an announcement to the subscriber with the number of the last caller (or an indication that the number was withheld) and prompts the user to confirm activation of the service.
- The BSS AS attempts to establish a call to the target (last caller) and connects the call to the subscriber if the target is not busy.
- If the target is busy, the BSS AS plays an announcement to the subscriber indicating that the service has been activated.

Once activated, the BSS AS is responsible for monitoring the state of the target.

For interoperability with other PacketCable endpoints (e.g., RST E-DVA, PacketCable 1.5 CMS, and MGC), the BSS AS MUST use procedures compatible with [RSTF]. In summary this consists of the following:

- The requestor's BSS AS sends an INVITE addressed to the target containing a Call-Info header with a purpose of "answer\_if\_not\_busy".
- On receiving a Busy (486 or 600) response code, the requestor's BSS AS sends a SUBSCRIBE for the dialog event package.
- The requestor's BSS AS waits until a NOTIFY is received indicating that the target is idle.

The requestor's BSS AS may use alternative methods for monitoring the state of the target where appropriate (for example, if it is also acting as the BSS AS for the target and is fully aware of the target's dialog state).

When the requestor's BSS AS receives an INVITE containing the AR deactivation VSC, it invokes the AR deactivation service logic. This will typically consist of the following steps:

- Canceling subscriptions at the target.
- The requestor's BSS AS plays an announcement to the subscriber confirming that the service has been deactivated.

## 7.5.1.2 Feature Execution

### 7.5.1.2.1 BSS AS

The BSS subscriber may be a target of AR monitoring requests from other users. The target's BSS AS MUST handle such monitoring requests on behalf of the BSS UE without requiring that the UE supports any special AR extensions or behavior. For interoperability with other PacketCable endpoints (e.g., RST E-DVA, PacketCable 1.5 CMS, and MGC), the BSS AS MUST be compatible with [RSTF]. The target's BSS AS is responsible for managing multiple subscriptions arising from multiple remote UEs requesting AR service from the target. The order in which the BSS AS honors subscriptions is outside the scope of this specification.

Both the requestor's and target BSS AS need to know when their subscriber's line is idle. The precise mechanism the BSS AS uses is outside the scope of this specification; however, it must not place any additional requirements on the UE. Possible mechanisms include:

- All calls originated from and terminated by the UE are routed through the BSS AS; the BSS AS determines the line state from the number of calls.
- The BSS AS monitors the line state of the UE using the mechanism described in Section 7.9.6.

When the target's BSS AS determines that the target line is idle, it sends a NOTIFY towards the requestor for the previously received subscription.

When the requestor's BSS AS determines that both the subscriber and target are idle, it MUST send an INVITE to the subscriber's UE with an Alert-Info header indicating that a special ringing pattern is to be used (Section 7.6.5). When the subscriber answers, the BSS AS establishes a call to the target and connects the call to the subscriber.



## 7.5.2 Automatic Callback

The Automatic Callback (AC) feature allows a UE to automatically call back the last called address, whether the call was answered by the called party or not. The AC feature should work even when the last call made from the UE was to an address not known by the subscriber. This happens when the last call from the AC requesting UE is an anonymous AR call.

The feature as described in this specification is implemented by the BSS AS and places minimal requirements on the UE. Whenever a public identity is subscribed to the AC feature, all calls placed from the public identity are sent via the BSS AS. The BSS AS records the details of the most recent originating call.

Based upon operator policy and subject to UE capability, the AC procedures described in [RSTF] may be used instead of the procedures described in this section. Alternatively, a UE compliant with [RSTF] can use the procedures described in this section through a trivial change to its digit map configuration.

### 7.5.2.1 Feature Activation and Deactivation

Similar to the AR feature, the user may invoke or revoke the AC feature via the telephony user interface by entering the AC activation or deactivation VSCs. The UE MUST send an INVITE with the Request URI containing the AC activation or deactivation code.

When the BSS AS receives the INVITE, it invokes the AC service logic. For activation, this will typically consist of the following steps:

- The BSS AS attempts to establish a call to the target (last called destination) and connects the call to the subscriber if the target is not busy.
- If the target is busy, the BSS AS plays an announcement to the subscriber indicating that the service has been activated.

Once activated, the BSS AS is responsible for monitoring the state of the target and alerting the subscriber when the target becomes idle using the same mechanism as the AR service. The BSS AS MUST implement these requirements from Section 7.5.1.1.

If the BSS AS receives an INVITE containing the deactivation code, the BSS AS deactivates the service using similar procedures as the AR service. The BSS AS MUST implement the requirements from Section 7.5.1.1.

### 7.5.2.2 Feature Execution

The subscriber may be a target of AC monitoring requests from other users, which are identical to AR monitoring requests from other users. The BSS AS MUST implement the requirements from Section 7.5.1.2.

### 7.5.2.3 Call Flows

AC call flows are very similar to AR call flows with the exception that the target is the last called address instead of the last calling address. See Section 7.5.1.3 for AR call flows.

## 7.5.3 Last Number Redial

The Last Number Redial feature enables a user to automatically redial the last called number by pressing a redial button on their telephone set.

### 7.5.3.1 Feature Execution

This feature is entirely implemented on the UE. When the Last Number Redial is invoked, the UE MUST send an INVITE with a Request URI identical to that sent in the INVITE for the last outgoing call.

## 7.6 Miscellaneous Features

### 7.6.1 Do Not Disturb (DND Client)

The Do-Not-Disturb Client feature allows the user to put a given UE associated with a public identity into a mode in which it does not alert on receipt of incoming calls. This feature is different from the Do-Not-Disturb Public Identity feature in that it affects only a single UE, not all UEs behind the public identity.

### **7.6.1.1 Feature Activation and Deactivation**

With the DND Client feature available, the user activates or deactivates the feature through some interaction with the UE. For instance, if the UE supports the analog telephony interface, the user can activate or deactivate the DND Client feature via the phone keypad by entering a VSC. If there are multiple UEs associated with a single public identity, only the UE that activated DND Client feature can deactivate the feature. No network signaling results from the act of activating or deactivating DND client.

When DND Client is activated, the UE SHOULD render a status indicator, either visual or audible when going off-hook, that the DND feature is activated.

The user may be able to program the criteria for DND Client. For instance, using a web portal, the user may be able to create and change the maximum duration of feature activation or the list of callers (with their public user identities) who are exempted from the DND Client treatment when the feature is in effect.

### **7.6.1.2 Feature Execution**

#### **7.6.1.2.1 UE**

A UE with DND client activated on reception of a new incoming dialog creating INVITE SHOULD reject this request with a 480 Temporary Failure final response. The UE MAY include a Warning header in the response with a warning code of 399 and warning text appropriate to DND.

### **7.6.2 Do Not Disturb (DND Public Identity)**

The Do-Not-Disturb Public Identity feature allows the user to put the public identity and all UEs behind it into a mode in which they do not alert on receipt of incoming calls. This feature is different from the Do-Not-Disturb Client feature in that it affects all UEs behind the public identity, not just the UE that activated the feature.

#### **7.6.2.1 Feature Activation and Deactivation**

The DND Public Identity feature availability is provisioned per public identity by the operator. If provisioned, the availability status applies to all the UEs registered to the public identity.

The user activates or deactivates DND Public Identity, for example, by dialing the appropriate feature code. The UE irrespective of the user interface provided, MUST construct a SIP INVITE (Section 6.4.1) including the defined feature code for DND Public Identity activation or deactivation. If there are multiple UEs associated with a single public identity, the activation status applies to all such UEs regardless from which UE the activation or deactivation has been applied.

Upon receipt of an INVITE with the DND Public Identity activation code, the BSS AS responds with a 200 OK. When the BSS AS receives the ACK from the UE, it MAY play a confirmation tone to the user before terminating the session with a SIP BYE.

For the case of a BSS AS and BSS UE supporting user notification of DND status as defined by [RSTF], the BSS MUST provide the DND feature activation status to the UE by SIP signaling as described therein.

The user may be able to program the criteria for DND Public Identity. For instance, using a web portal, the user may be able to create and change the maximum duration of feature activation or the list of callers (with their public user identities) who are exempted from the DND Public Identity treatment when the feature is in effect.

#### **7.6.2.2 Feature Execution**

##### **7.6.2.2.1 BSS AS**

The BSS AS, on reception of a new incoming dialog-creating INVITE for a user who has activated DND, SHOULD reject this request with a 603 Decline final response. The UE MAY include a Warning header in the response with a warning code of 399, and warning text appropriate to DND.

### **7.6.3 Screening List Editing (SLE)**

The SLE feature allows users to create and update lists of public identities (in the form of the Directory Number, Tel, or SIP URI) associated with features that require these lists, such as Selective Call Forwarding, Distinctive Alerting, and Do Not Disturb. This feature also allows the user to activate/deactivate features that use lists and obtain feature status reports.

### **7.6.3.1 Feature Execution**

As this feature is entirely provided by a BSS AS, there are no additional SIP interface requirements to be defined.

### **7.6.4 Subscriber Programmable PIN**

The subscriber programmable Personal Identification Number (PIN) feature allows a subscriber to manage PIN codes for features that require personal identification numbers.

#### **7.6.4.1 Feature Execution**

As this feature is entirely provided by a BSS AS, there are no additional SIP interface requirements to be defined.

### **7.6.5 Distinctive Alerting**

UEs are user-configurable or provisionable to provide customized alerting behaviors (audible, visual, vibration, etc). The behavior used in any given condition:

- May be selectable through feature definition on the part of an operator.
- May be selectable by end-user configuration.
- May be selectable based on received call signaling, at a minimum based upon the public identity that is called and/or the public identity that is calling, by the UE and/or by the network.

#### **7.6.5.1 Feature Activation and Deactivation**

The availability status of the Distinctive Alerting feature is provisioned by the service provider as part of the service provisioning for a user. The associated provisioning procedures are outside of the scope for this specification.

With the Distinctive Alerting feature activated, the UE MAY be able to initiate an SLE session to configure the public identities that cause distinctive alerts when an INVITE from any of these public identities is received.

#### **7.6.5.2 Feature Execution**

##### **7.6.5.2.1 UE**

The UE MUST follow the Distinctive Alerting requirements in [RSTF] for feature execution. In particular, the UE MUST support the baseline set of alert patterns given in [RSTF].

##### **7.6.5.2.2 BSS AS**

The BSS AS MUST follow the Distinctive Alerting requirements in [RSTF] for feature execution. In particular, the BSS AS MUST support the baseline set of alert patterns given in [RSTF].

### **7.6.6 Message Waiting Indicators**

Message Waiting Indicators (MWI) are presented when a message has been received by the network for the public identity associated with the UE. Traditionally a message is a voice mail, but may be extended to additional message types based on additional to-be-defined feature definitions.

#### **7.6.6.1 Feature Execution**

##### **7.6.6.1.1 UE**

The UE MUST follow the MWI requirements in [RSTF] for feature execution.

##### **7.6.6.1.2 BSS AS**

The BSS AS detects status changes of the message account. The actual detection mechanism is outside of the scope for this specification, but may involve the BSS AS's signaling with an embedded or standalone message storage and processing system.

The BSS AS notifies the status change of the message account to the UE as an MWI. This notification follows the general process of SIP event subscription/notification. Once received, the MWI is presented by the UE to the user as a visual signal and/or an audible signal.

The BSS AS MUST follow the MWI requirements in [RSTF] for feature execution.

## 7.6.7 Speed Dialing

The network-based Speed Dialing feature allows the user to dial frequently called public user IDs, by assigning them either one-digit or two-digit speed-dialing codes.

### 7.6.7.1 Feature Activation and Deactivation

The availability status of the Speed Dialing feature is provisioned by the service provider as part of the service provisioning for a user. The associated provisioning procedures are outside of the scope for this specification.

With the feature provisioned, the subscriber may be able to initiate the programming of the speed-dialing list by entering a VSC (for example, \*74 for one-digit Speed Dialing and \*75 for two-digit Speed Dialing). Alternatively, a web portal can also be provided to the user by the service provider for programming the speed-dialing list. In either case, the requirements for the valid speed-dialing codes in Telcordia [GR 570] should be followed.

### 7.6.7.2 Feature Execution

#### 7.6.7.2.1 UE

When the user invokes the Speed Dialing feature, the UE MUST populate the RequestURI of the INVITE with the dialed speed-dialing code.

#### 7.6.7.2.2 BSS AS

Upon receiving an INVITE request with a RequestURI containing a speed-dial code, the BSS AS MAY perform the necessary authorization to determine whether or not the Speed Dialing feature is activated for the originating UE. If the authorization fails, the BSS AS SHOULD respond to the INVITE with a 403 Forbidden response to reject the call attempt. If the authorization succeeds, the BSS AS maps the speed-dialing code in the Request URI into the public user ID of the intended destination party. If the mapping is successful, the BSS AS MUST replace the original Request URI in the received INVITE with the resulting public user ID of the intended destination party, and forward the resulting INVITE. If the mapping fails (that is, there is no entry corresponding to the speed-dialing digit), the BSS AS MUST fail the call attempt with an appropriate 4XX final response.

## 7.6.8 Customer-Originated Call Trace

The Customer-Originated Call Tracing (COT) feature allows the receiver of an obscene, harassing, or threatening call to initiate a call trace. This terminating call feature is often called Malicious Call Tracing, but the COT feature adds the capability for the offended party to invoke the trace. After the offended customer invokes the call trace procedure, the appropriate service authorized agency handles the disposition of the malicious call or calls.

The feature as described in this specification is implemented by the BSS AS and places minimal requirements on the UE. Whenever a public identity is subscribed to the COT feature, all calls placed to the public identity are sent via the BSS AS. The AS records the caller's public identity and other relevant call-related information (for example, date and time) of the most recent terminating call.

Based upon operator policy and subject to UE capability, the COT procedures described in [RSTF] may be used instead of the procedures described in this section. Alternatively, a UE compliant with [RSTF] can use the procedures described in this section through changing the digit map so that matching against the COT activation VSC invokes the MAKE-CALL action passing into it all dialed digits rather than the COT-ACTIVATE action specified in [RSTF].

### 7.6.8.1 Feature Execution

#### 7.6.8.1.1 UE

The subscriber activates the COT feature, for example, by dialing the COT activation VSC. The UE MUST send an INVITE with the Request URI containing the COT activation code.

#### 7.6.8.1.2 BSS AS

When the BSS AS receives an INVITE containing the COT activation VSC, it invokes the COT activation service logic. This will typically consist of the following steps:

- The BSS AS identifies details of the last incoming call. For the case where multiple UEs are registered for the same public identity, the BSS AS may identify the last incoming call to the UE making the COT request by

comparing Contact information in the received INVITE with Contact information observed in responses to recent incoming calls.

- If the BSS AS is configured for two-stage activation, it plays an announcement to the subscriber, which prompts the user to confirm activation of the service.
- Once activated, the BSS AS provides details of the traced call to the appropriate service agency. This interface is outside the scope of this specification.

If the BSS AS is unable to trace the call, the BSS plays an appropriate announcement to the subscriber.

## 7.7 Operator Services

PacketCable Business SIP Services uses the operator services mechanisms described in [RSTF]. Operator Services consists of two related features: Busy Line Verification and Operator Interrupt.

The requirements and interface definition for both Busy Line Verification and Operator Interrupt are as defined in [RSTF].

## 7.8 Emergency Services

### 7.8.1 Assumptions

When initiating a session to an emergency services address, a UE in NENA i2 and NENA i3 environment supplies its current location information within the signaling for the session, in order to allow the call routing network elements to direct the call to the correct Public Safety Answering Point (PSAP) and aid emergency services personnel in providing emergency services to the initiator.

A user initiates an emergency session by using a registered UE to initiate a session to an emergency address. The emergency call is routed locally to the PSAP serving the location.

In this section, the emphasis is put on the UE requirements, and network requirements that are specific to the Business Services environment defined by this specification.

Various versions of NENA are supported, namely NENA i1, pre-i2, i2, and i3. Refer to [RSTF] for a brief description of various NENA versions.

The following assumptions are made.

- For UEs that are required to operate in a NENA i2 and NENA i3 environment, the following apply:
  - These UEs support the DHCP protocol and the associated DHCP options for geographical location [RFC 3825] and civic location [RFC 4676]. The UE also supports SIP multipart MIME as specified in [RFC 3261] to convey location information in SIP message bodies as defined below.
  - These UEs operating behind local DHCP servers (for example, UEs behind NAT), the location information DHCP option should be relayed. In the absence of a DHCP relay for the location information, a dynamic location may not be reliably provided by the UE, and the Emergency-Call Session Control Function (E-CSCF) handles the emergency call without location and attempts to do a static mapping to a default PSAP.
  - All UEs support SIP Location Conveyance [ID SIP-CONVEY]).
- Only registered and authenticated UEs will be allowed to originate an emergency call.
- UEs support configuration of a specific DSCP value for IP packets carrying the media of the emergency call.
- Core network is compliant with [PKT 24.229].
- In NENA i1, NENA pre-i2 and NENA i2 environment, a PSAP call back to the public user ID of the user may result in a non-emergency terminating call, as the PSTN network may not have the capability to indicate that it is an emergency call. Thus, the PacketCable network is not aware that this is an emergency call, therefore normal terminating features for that UE would apply.

## 7.8.2 Emergency Calling

### 7.8.2.1 UE configuration

The following configuration parameters are provided to a UE in support of emergency calling:

- A list of dial numbers that must be recognized as emergency numbers by the UE.
- In the case of NENA i2 and NENA i3:
  - the UE's location information: a set of location parameters obtained via DHCP.
  - the preference for the type of location format (Presence Information Data Format - Location Object, or PIDF-LO) the UE should include if it gets both civic and geographic location information via DHCP.
- DSCP value to be used for uplink IP packets carrying the emergency media.

The UE **MUST** be capable of handling emergency calls, even when one or more of the configuration parameters above are not provided, with the exception of the list of emergency numbers. For example, the UE may handle the call without prioritization or media QoS if the associated configuration parameters are not provided, but it **MUST** attempt to place the emergency call.

It should be noted that if a UE does not recognize an originated call as an emergency call, it may result in the network recognizing it as an emergency call, and route it to the PSAP.

### 7.8.2.2 UE Emergency Call Recognition

The UE **MUST** recognize that a certain originated call is an emergency call by comparing the number dialed with the list of configured emergency numbers. If there is a match, the UE **MUST** implement the requirements in Section 7.8.2.3. Otherwise, the UE treats the call as a non-emergency call.

It should be noted that, based on operator policy, the Proxy - Call Session Control Function network (P-CSCF) may perform emergency call recognition in the PacketCable network and proceed to deliver the call towards the PSAP, even if the UE did not recognize the call as an emergency call. In this case, the network operates as specified in [PKT 24.229] for emergency calls.

### 7.8.2.3 UE originated SIP INVITE for Emergency Calls

The UE generates a SIP request to initiate a call and sends it to the P-CSCF. In addition to following the UE emergency procedures specified in [PKT 24.229] section "Emergency session setup within a non-emergency registration," the UE **MUST** populate the SIP INVITE request initiating an emergency call as follows:

- SIP signaling identification of an emergency call as described in Section 7.8.2.4.
- The SDP message body part. The G.711 codec **MUST** be offered in the media line attribute as per [CODEC MEDIA]. If a wideband codec is supported by the UE, it **MAY** be offered as an additional choice. The UE **MUST NOT** offer any other codecs. Voice Activity Detection **SHOULD** be disabled.

The UE **SHOULD** include a language preference whenever possible, according to [PKT 24.229].

Furthermore, for UEs operating in NENA i2 and NENA i3 environment, the UE **MUST** include in the SIP INVITE:

- The UE location as specified in [PKT 24.229] in the multi-part MIME message body.
- Request-URI set to the emergency service URN as specified in [PKT 24.229] and [RFC 5031].

### 7.8.2.4 Signaling Identification of an Emergency Call

Once a call has been determined to be an emergency call (see Section 7.8.2.2), additional requirements are applied to the signaling to ensure proper priority of the call and the signaling through the use of SIP Priority header [RFC 3261].

The SIP Priority header provides a user indication of the importance that the SIP request should have for the receiving human or user agent. The Priority header field does not affect the usage of PSTN gateway or proxy resources. The UE **SHOULD** set the SIP Priority header for emergency session establishment.

Example:

Priority: emergency

### 7.8.3 Location Identification

In NENA i2 and NENA i3 environment, the UE is responsible for obtaining its location. A UE MUST be capable of receiving its location via DHCP by processing the DHCP options that provide the civic address or coordinate-based (geographic) location configuration information.

A UE MUST support the GEOCONF CIVIC DHCP option defined in the [RFC 4676]. The UE SHOULD also support GeoConf DHCP option 123 defined in [RFC 3825]. A UE MUST request the GEOCONF CIVIC DHCP option in DHCP option 55 in IPv4, and in the Option Request Option in DHCPv6. If both the DHCP GeoConf and GEOCONF CIVIC options are supported, the UE MUST indicate or request both options in DHCP.

The resulting location information is then used by the UE to create a PIDF-LO using the mechanism described and illustrated in [RFC 4119]. The UE MUST use the value of the GEOCONF CIVIC DHCP option to generate a PIDF-LO if both DHCP options 123 and 99 are returned by the DHCP server.

The UE MUST store the location information, along with the timestamp of when it receives its location information, via DHCP. The UE MUST include a timestamp element in the PIDF-LO generated from the DHCP location information object. The UE MUST set the value of the timestamp element to be the time when the UE receives its location information.

### 7.8.4 SIP Location Conveyance

In NENA i2 and NENA i3 environments, when the UE registers it SHOULD indicate support for the location, as defined in the SIP Location Conveyance specification [ID SIP-CONVEY]. In particular, the UE MUST support SIP multipart MIME, as specified in [RFC 3261], to convey location information in SIP message bodies.

### 7.8.5 Media and Signaling QoS for an Emergency Call

A UE that has recognized an origination call as an emergency call MUST mark the outgoing IP packets carrying the media of the emergency calls with special DSCP values based on the UE configuration parameters. Refer to Section 6.5 for more information

## 7.9 Business-Oriented Individual Line Feature

### 7.9.1 Automated Attendant (Auto-attendant)

The Auto-Attendant feature allows incoming calls to be automatically transferred to the appropriate extension or destination (e.g., voice-mail) without intervention of a human receptionist. The auto-attendant function typically utilizes an Interactive Voice Response (IVR) system to provide prompts to the originator, and then routes calls based on the responses provided to the prompts.

#### 7.9.1.1 Feature Execution

##### 7.9.1.1.1 BSS AS

The Automated Attendant feature is entirely executed in the BSS AS. Customer premise equipment (CPE) based auto-attendants are outside the scope of this specification. An example set-up sequence for the BSS AS is listed below.

1. Calls terminate to the auto-attendant via standard SIP signaling, and the auto-attendant answers the call.
2. The auto-attendant plays announcements to the caller and collects DTMF digits.
3. The auto-attendant may transfer the call to another destination using standard SIP signaling (such as the REFER method).

The BSS AS MUST allow multiple simultaneous sessions to terminate to automated attendant, with each session being handled independently of the others.

## 7.9.2 Direct Inward Dialing, Direct Outward Dialing (DID/DOD)

Direct Inward Dialing and Direct Outward Dialing is the default behavior in a PacketCable network – all user terminals assigned an E.164-compliant directory number (DN) can directly send or receive calls to/from the PSTN unless restricted by call blocking features. DID can be allowed or blocked on a per-user basis for the listed DNs associated with either Selective Call Acceptance (Section 7.3.3), or Selective Call Rejection (Section 7.3.4). Inward collect calls can also be blocked (Section 7.3.2). DOD can be blocked on a user basis by invocation of the Outbound Call Blocking feature (Section 7.3.1).

## 7.9.3 Extension Dialing (Private Numbering Plan)

The Extension Dialing feature allows one Business Group (BG) user to call another user within the Business Group using a short code, and typically is offered as a feature within a private dial plan. A private dial plan may offer other features, such as allowing a predefined external destination to be called, and may use one or more prefix digits to disambiguate between a number inside the PNP and a number outside the PNP (e.g., prefixing an external number with a "9").

### 7.9.3.1 Feature Execution

#### 7.9.3.1.1 UE

When the user dials an extension, the UE passes the dialed digits to the network in the Request URI of an INVITE as described in Section 6.4.1. If a digit map is used, it needs to be consistent with the user's Private Number Plan.

When a UE receives an incoming call, "internal" Caller ID can be obtained using the From header (see Section 7.1.1 and Section 7.9.3.1.2.2).

#### 7.9.3.1.2 BSS AS

##### 7.9.3.1.2.1 Call Origination

Upon receiving the INVITE, the BSS AS checks whether the dialed digit string contained within the Request URI is permitted within the Private Number Plan. If the digits are valid (permitted within the Private Number Plan), the BSS AS MUST replace the original Request URI with the public identity of the intended destination party in the INVITE returned to the S-CSCF. If the digits are not permitted in the PNP (e.g., unrecognized extension), the BSS AS MUST indicate the failure to the user (for example by rejecting the INVITE or playing an appropriate announcement).

##### 7.9.3.1.2.2 Internal Caller ID

The BSS AS SHOULD support a feature where the internal extension name and number is displayed as Caller ID for calls made between extensions within the same Business Group. If supported, the BSS AS MUST ensure that the From header included in INVITEs sent towards the UE, contains the desired calling name and number information to be displayed (as defined in Section 7.1.1). To prevent issues arising within the core PacketCable network, the BSS AS SHOULD NOT remove or modify the P-Asserted-Identity header to contain a private identity.

##### 7.9.3.1.2.3 Private Extensions

The BSS AS may support a feature where some "private" extensions in the BG are not assigned a unique public E.164 identity; this emulates function traditionally found on a PBX.

**Note:** The PacketCable core network requires that all subscribers have distinct Public User Identities. It is, therefore, not possible to support extensions that are truly "private", although the core network does not require that Public User Identities are dialable E.164 numbers.

A private extension can be called from other extensions within the BG by dialing the appropriate extension number. Calls originating from outside the BG can only reach the private extension by being transferred from another extension or attendant. The execution of the extension dialing feature as described above is unaffected by whether the called extension has a public E.164 number or not – the BSS AS substitutes the dialed extension with the Public User Identity of the target.

The Caller ID for external calls originating from a private extension traditionally identifies the E.164 number of a "public" extension within the BG (typically the main number for the business that connects to an attendant).

- For non-emergency external calls, the BSS AS MAY prevent disclosure of a private extension's Public User Identity by overwriting the P-Asserted-Identity header with the Public User Identity of the desired public extension.
- For emergency calls, the call is routed towards the PSAP without BSS AS involvement (see Section 7.8.2). If private extensions are deployed in networks where the calling number must contain a valid E.164 number (e.g., NENA i1), the Public User Identity of the private extension needs to be chosen so that the desired public E.164 number is signaled to the PSAP; it is recommended that the extension convention defined in [RFC 3966] is used (e.g., "tel:+12222222222;ext=102" or the SIP URI equivalent obtained using the conversion algorithm described in [RFC 3261]).

#### **7.9.4 Alternate Number (Virtual Number, Second Number)**

The Alternate Number feature allows users to have multiple directory numbers that all terminate on the same subscriber line. The main number assigned to the subscriber is referred to as the primary number.

##### **7.9.4.1 Feature Execution**

###### **7.9.4.1.1 UE**

The UE has no requirements for support of Alternate Number functionality other than optional basic support for the Alert-Info header for custom alerting for calls to an alternate number.

###### **7.9.4.1.2 BSS AS**

The essential aspects of the Alternate Number feature are provided by the BSS AS. The solution is interoperable with Remote Call Forwarding [GR 581], avoiding the need for the Alternate Number to be "owned" by the PacketCable network. The following example describes the case where the donor domain and recipient domain are both PacketCable Networks (although they don't need to be the same PacketCable network).

1. Calls to the Alternate Number are routed to the donor domain as normal.
2. The BSS AS in the donor domain forwards the call to the primary number using a similar process to Call Forwarding Variable (Section 7.2.1). To allow identification of the original dialed number and provide loop detection, the donor domain inserts a History-Info header in each forwarded INVITE request targeted to the alternate number.
3. The BSS AS in the recipient domain MAY use the received History-Info header and local configuration to identify a call to the alternate number and implement distinctive alerting inserting an Alert-Info header, custom call routing, and special handling for voice mail.

#### **7.9.5 Intercom (Group Intercom, Push-to-talk)**

The Intercom feature allows a user to place a call to a feature phone configured to auto-answer and enable the speaker and, optionally, the microphone, on the called feature phone for that class of call. Only feature phones equipped with speakerphone can accept intercom calls.

##### **7.9.5.1 Feature Execution**

###### **7.9.5.1.1 UE**

To initiate an intercom call, the UE sends an INVITE containing the Intercom VSC followed by an extension number or abbreviated number of the called phone as described in Section 6.4.1. For example, a user with an analog-style interface could go off hook and dial '7' + <extension number> to initiate the feature. A non-analog UE may provide an alternative user interface (e.g., automatically initiating the call to a preconfigured destination when a key is pressed).

UEs supporting Auto-Answer (Section 6.4.4) MUST accept intercom calls. The UE may be locally configured to support a one-way (receive-only) answer mode for intercom calls. If the called UE supports this, it places an "a=recvonly" attribute in the answer. To create a 2-way talk path after the called UE is signaled by the user by some means, the called UE generates a new offer in a re-INVITE with an "a=sendrecv" attribute in the SDP.

### 7.9.5.1.2 BSS AS

All essential aspects of the feature are provided by the BSS AS as follows:

1. Upon receipt of the INVITE, the BSS AS parses the dialed number and converts it to a normalized URI using local intercom configuration for extensions and abbreviated numbers embedded in the dial string.
2. The BSS AS **MUST** insert an Answer-Mode header as described in Section 6.4.4. The BSS AS **MAY** use the Priv-Answer-Mode header to force the UE to auto-answer the intercom call when it is in-use. The BSS AS **MAY** also add an Alert-Info header to provide a custom intercom announcement signal.
3. The called UE receives the INVITE containing the Answer-Mode header and automatically answers.

The BSS AS may be configured to enable one-way (receive-only) answer mode. In this case the BSS AS includes an "a=sendonly" attribute in the Session Description Protocol offer (instead of "a=sendrecv").

## 7.9.6 Shared Call Appearance (Multiple Appearance Directory Number – MADN)

The shared call appearance (SCA) application allows for a call appearance associated with a single address or directory number to be shared across multiple members of an SCA group. When an incoming call is received for this number, all of the group members sharing the call appearance will simultaneously alert, and the first member that answers the call is connected to the incoming call. Once a call is active with one group member, the other members of the group are not allowed to initiate or receive new calls on the shared appearance. The member who answered the call may place the call on hold, after which the call may be retrieved by another member of the group.

### 7.9.6.1 Feature Execution

**Note:** The intention here is to align the feature execution with the IETF BLISS working group where possible. This BLISS activity is still in progress with work focusing on [ID JOHNSTON-BLISS-MLA]. Some open issues remain with this draft. Once the BLISS activity has completed, the intention is to update this section to retain alignment. The main purpose of this section is to outline how the concepts identified in [ID JOHNSTON-BLISS-MLA] correspond to components within the PacketCable network. Further study is needed to determine whether the SUBSCRIBE, PUBLISH, or INVITE method from [ID JOHNSTON-BLISS-MLA] should be supported (this section currently assumes SUBSCRIBE).

Depending on the implementation, the SCA application may be configured to manage a single shared call appearance for the group, or multiple shared call appearances. The BSS AS is responsible for managing the shared call appearances within the group. If the group is configured to support multiple shared call appearances, the BSS AS ensures the integrity of the call appearance identifiers used within the group, and enforces that the group doesn't exceed a configured maximum number of simultaneous active sessions. In addition to the BSS AS, the UE associated with each member of the group will be required to support specific service logic for actions that it initiates as a part of the application. The architecture of the service follows the work underway in the IETF BLISS study group, specifically documented in [ID JOHNSTON-BLISS-MLA]. The BSS AS **MUST** support [ID JOHNSTON-BLISS-MLA], [RFC 3265], [RFC 4235], and [RFC 5627]. UEs supporting SCA **MUST** support [ID JOHNSTON-BLISS-MLA], [RFC 3265], [RFC 4235], and [RFC 5627]. In addition the BSS AS **MUST** support [RFC 3680].

SCA service execution logic can be broken into five phases:

- The first phase involves actions that take place when a member of an SCA group registers with the network.
- The second phase involves actions that take place when a member of the group initiates a session on the shared call appearance.
- The third phase involves actions that take place when a call terminates to a shared call appearance.
- The fourth phase involves actions that take place if one member holds an active call, which is later retrieved by a different group member.
- The fifth phase involves actions that take place when an SCA group member attempts to bridge into an active call.

The first four phases are described in this section, while the fifth phase is covered in Section 7.9.7.

Prior to registration, the BSS AS is assumed to have been configured with the public user identity (DN) used to terminate calls to the group. The iFC associated with the shared public user identity is configured to direct all terminations destined to that user to the BSS AS.

#### 7.9.6.1.1 Registration Phase

In order for the SCA application to manage each of the sessions associated with the group, it is necessary for the BSS AS and each member's UE to be aware of all dialogs in the SCA. Notifications from the member's UE to the BSS AS are necessary for the UE to confirm a call appearance for a call origination, as well as to notify the BSS AS when the UE answers a session. Notifications from the BSS AS to the UE are required so that the BSS AS can notify the member's UE when another group member has answered or released an active session. The BSS AS uses third-party registrations and the reg event package to discover when public user identity for the group registers on each of the member UEs (see [PKT 24.229] and [RFC 3680] for details).

1. Each member UE of the SCA group is configured to register with the public identity for the group, specifically the "SCA Group URI" defined in Table 4. The registration is challenged and authenticated per normal procedures in the PacketCable core network. By assigning each UE a distinct Private User Identity (see [PKT 24.229]), each UE can register with a unique set of credentials.
2. As the SCA Group URI registers on each member UE, the PacketCable core network sends a reg event NOTIFY to the BSS AS (see [PKT 24.229] and [RFC 3680]).
3. The BSS AS receives the NOTIFY and sends a dialog state SUBSCRIBE to the GRUU of the newly registered SCA Group URI as specified in [ID JOHNSTON-BLISS-MLA]. This subscription allows the BSS AS to be notified each time an SCA group member initiates or answers an SCA call. The subscription also provides a reference address of the "state agent" on the BSS AS to which the UE should direct its subsequent SUBSCRIBE for dialog event notifications for the group.
4. The UE responds to the SUBSCRIBE with a 200 OK and provides an initial NOTIFY containing its current dialog state (as [RFC 3265]).
5. The UE sends its own dialog event SUBSCRIBE to the BSS AS (identified as the "state agent").
6. The BSS AS responds to the SUBSCRIBE with a 200 OK and provides an initial NOTIFY reflecting the dialog state of the group.

This service logic is repeated as each subsequent member of the group registers. These actions result in an active subscription to the dialog event package in each direction between each group member and the BSS AS.

#### 7.9.6.1.2 Call Origination Phase

A subscriber attempts to initiate a new session on a shared call appearance.

1. The UE sends a dialog state NOTIFY towards the BSS AS as specified in [ID JOHNSTON-BLISS-MLA]. This contains a reference to the specific call appearance number, which the UE would like to associate with the session. The call appearance selected must be within the "Maximum Call Appearances" limit defined in Table 4. It is up to the UE to implement the mechanism for selecting the specific value used for the call appearance, possibly relating it to a button or key pressed on the UE. Preferably the UE does not provide dial tone to the user or initiate digit collection for the new call leg until a positive response has been received to the NOTIFY for that specific call appearance.
2. The BSS AS receives the NOTIFY and validates the request to seize the call appearance number. If the requested call appearance is invalid or already in use, the BSS AS notifies the UE as specified in [ID JOHNSTON-BLISS-MLA] and the call origination attempt is denied to the user. If the requested call appearance is valid and not already in use, the BSS AS approves the request by returning a 200 OK response to the NOTIFY and reserves the call appearance value for the new session that the UE will create.
3. The BSS AS sends a NOTIFY to each UE in the group as specified by [ID JOHNSTON-BLISS-MLA]. The UEs can use this notification to know that a particular shared call appearance is involved in a new call origination, and reflect to the user as appropriate through the UE's interface.

4. The originating UE receives the 200 OK response to the NOTIFY and allows the user to begin a new call. Once the called party address has been collected from the user using normal call origination processes, the UE sends a normal INVITE for the call.
5. When the session is answered, the originating UE receives a 200 OK response to the INVITE. As specified by [ID JOHNSTON-BLISS-MLA], the originating UE sends a NOTIFY to the BSS AS reflecting the dialog state as "confirmed".
6. The BSS AS receives the NOTIFY and in turn generates a corresponding dialog state NOTIFY that is sent to each UE in the group. The UEs can use this notification to know that a particular shared call appearance is now in the confirmed state and reflect to the user as appropriate through the UE's interface.

It is possible that a specific UE might host multiple other identities in addition to the identity of the shared call appearance. The UE should only include the reference to the call appearance number in dialog notifications associated with sessions that are created using the shared call appearance. The BSS AS may receive dialog notifications for UE sessions associated with identities besides the shared call appearance. The BSS AS should acknowledge these notifications without any further processing.

#### 7.9.6.1.3 Call Termination Phase

A call is received destined for the public identity of the SCA.

1. The BSS AS receives the INVITE for the new call termination and reserves a call appearance number to this specific session so that it cannot be leveraged by other calls originating or terminating with the group. If there is only one call appearance and this is currently being used by a specific UE, the BSS AS may choose to direct further calls only to this UE (resulting in call waiting). The BSS AS achieves this by updating the request URI of the INVITE to contain the GRUU of the appropriate UE.
2. The BSS AS inserts a reference to the assigned call appearance number in the Alert-Info header of the INVITE as specified by [ID JOHNSTON-BLISS-MLA].
3. The BSS AS directs the INVITE back to the PacketCable core network. Unless the INVITE contains a GRUU, the INVITE is forked to each UE registered for the SCA.
4. Each UE receiving the INVITE uses the call appearance number included in the Alert-Info header when presenting the session to the user (e.g., by lighting a key associated with the call appearance). While this call is being presented to the subscriber, the UE will not attempt to use the same call appearance number with any new sessions originating from the UE. The UE will apply normal termination procedures to this call, including any interactions with other terminating services, such as call waiting. If for whatever reason the UE is unable to accept the new termination, it will respond to the INVITE with an appropriate 400-series response.
5. When one of the alerting UEs answers the new call, it will perform the following two actions:
  - The UE will respond to the INVITE with a 200 OK. This results in the PacketCable networking cancelling other forked dialogs.
  - The UE will send a dialog event NOTIFY towards the BSS AS as specified by [ID JOHNSTON-BLISS-MLA]. The BSS AS in turn sends corresponding NOTIFY messages to other UEs in the SCA, allowing the SCA state to be reflected to the user as appropriate through the UE's interface.

#### 7.9.6.1.4 Call Hold / Retrieve Phase

Once an SCA member is involved in an active session, the session may be placed on hold by the member, and subsequently retrieved by the same or a different member of the group.

1. A member's UE places a session on hold as normal (see Section 7.4.2).
2. When the UE receives a 200 OK in response to the re-INVITE, it sends a dialog event NOTIFY towards the BSS AS indicating that the session has been placed on hold as specified by [ID JOHNSTON-BLISS-MLA].
3. Upon receiving this notification, the BSS AS sends separate dialog event NOTIFY messages to each UE in the SCA. Each UE can leverage this notification to provide an indication to the user that the active session is now on hold. This indication could take any one of several forms, depending on the capabilities of the UE.

At this point, the session is available for retrieval by any member of the group.

4. A UE can retrieve the session by sending an INVITE, including the Replaces header and a reference to the session that it would like to retrieve. The contents of the Replaces header is taken from the recent dialog notification associated with the call appearance that is being retrieved. The Request URI in the INVITE identifies the remote user indicated in the dialog notification, but filter criteria configured in the PacketCable network routes the INVITE to the BSS AS.
5. Upon receiving the INVITE, the BSS AS may take one of two actions:
  - The BSS AS may reconfigure the connections to each of the UEs involved in the call. Acting as a B2BUA, the BSS AS analyzes the Replaces header to determine which call appearance the UE is attempting to retrieve. The BSS AS responds by initiating codec negotiation between the held party and the member who is retrieving the session. After a media path has been negotiated, the BSS AS will send a BYE to the group member who was initially involved in the session.
  - The BSS AS may relay the INVITE with Replaces directly to the originating UE. This method may be used in scenarios where connection management is performed directly in the UEs, as opposed to the network.
6. Once the retrieving UE receives a 200 OK response to the INVITE, it sends a dialog event NOTIFY to the BSS AS indicating the session is now active as specified by [ID JOHNSTON-BLISS-MLA].

#### 7.9.6.1.5 Maintaining integrity of call appearance values

The BSS AS is responsible for managing the specific call appearance values in the group and maintaining the integrity of the call appearance values as they are associated with individual sessions. It must support mechanisms that can recover from scenarios where group members become isolated or non-responsive, possibly while a call appearance value has been associated with an active dialog on that UE. Several techniques can be used to maintain the integrity of the call appearance values, including those noted in [ID JOHNSTON-BLISS-MLA].

#### 7.9.6.2 Feature Data

Table 4 summarizes the feature data items that are defined in the UE to support the shared call appearance bridging feature.

**Table 4 - Shared Call Appearance UE Data**

Data	Type	UE Persistence	Scope	UE Provisioning
SCA Group URI	String	Non-volatile	Per SCA group	Mandatory Writable
Maximum Call Appearances	Integer	Non-volatile	Per SCA group	Mandatory Writable

#### 7.9.6.3 Call Flows

Figure 7 shows an example call flow when a UE registers. Figure 8 shows an example call flow when a UE originates a call. Figure 9 shows an example call flow when a call terminates to a SCA line. Figure 10 shows an example call flow showing a call being held by one UE and then retrieved from a different UE.

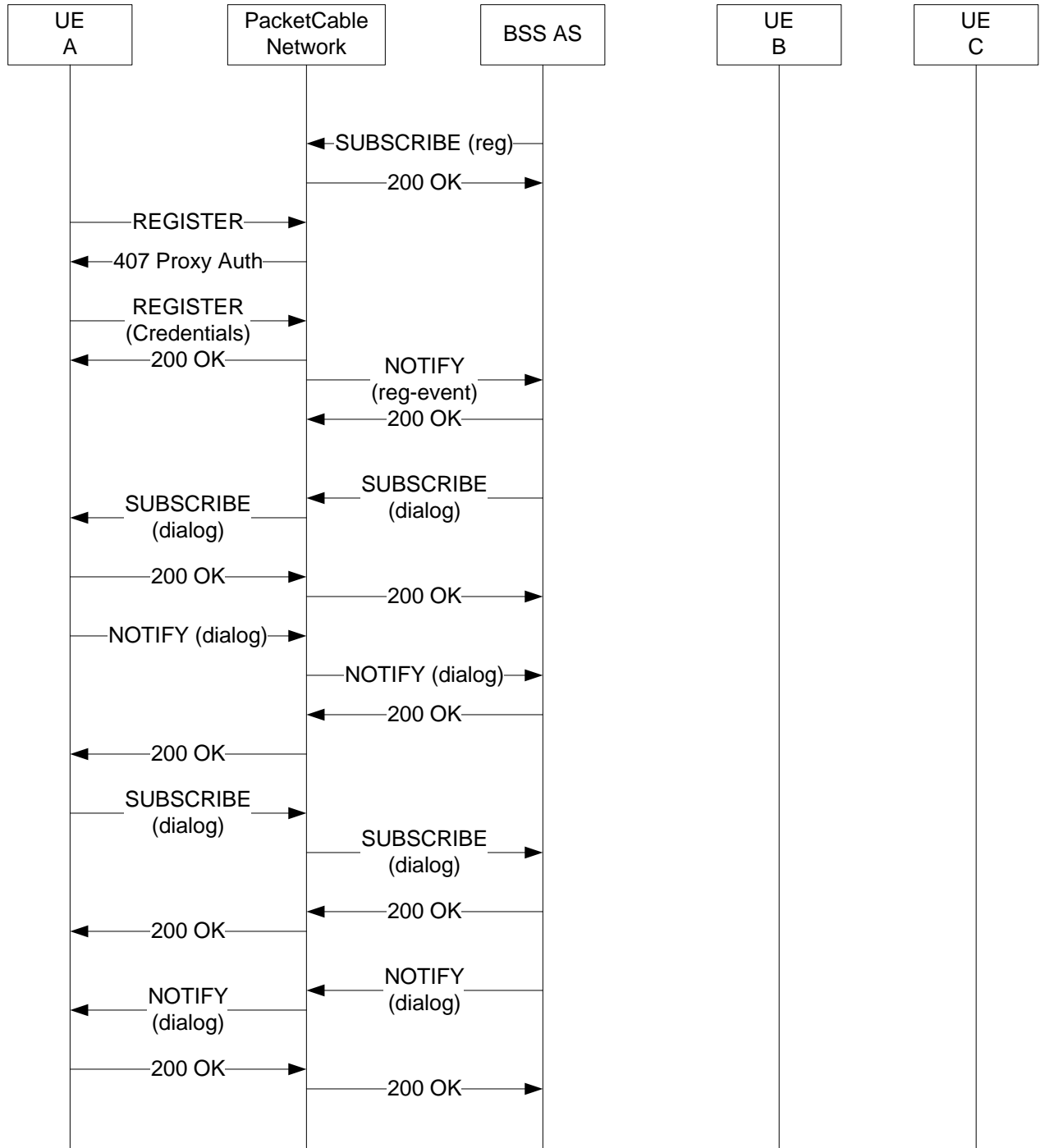

Figure 7 - SCA Registration Phase

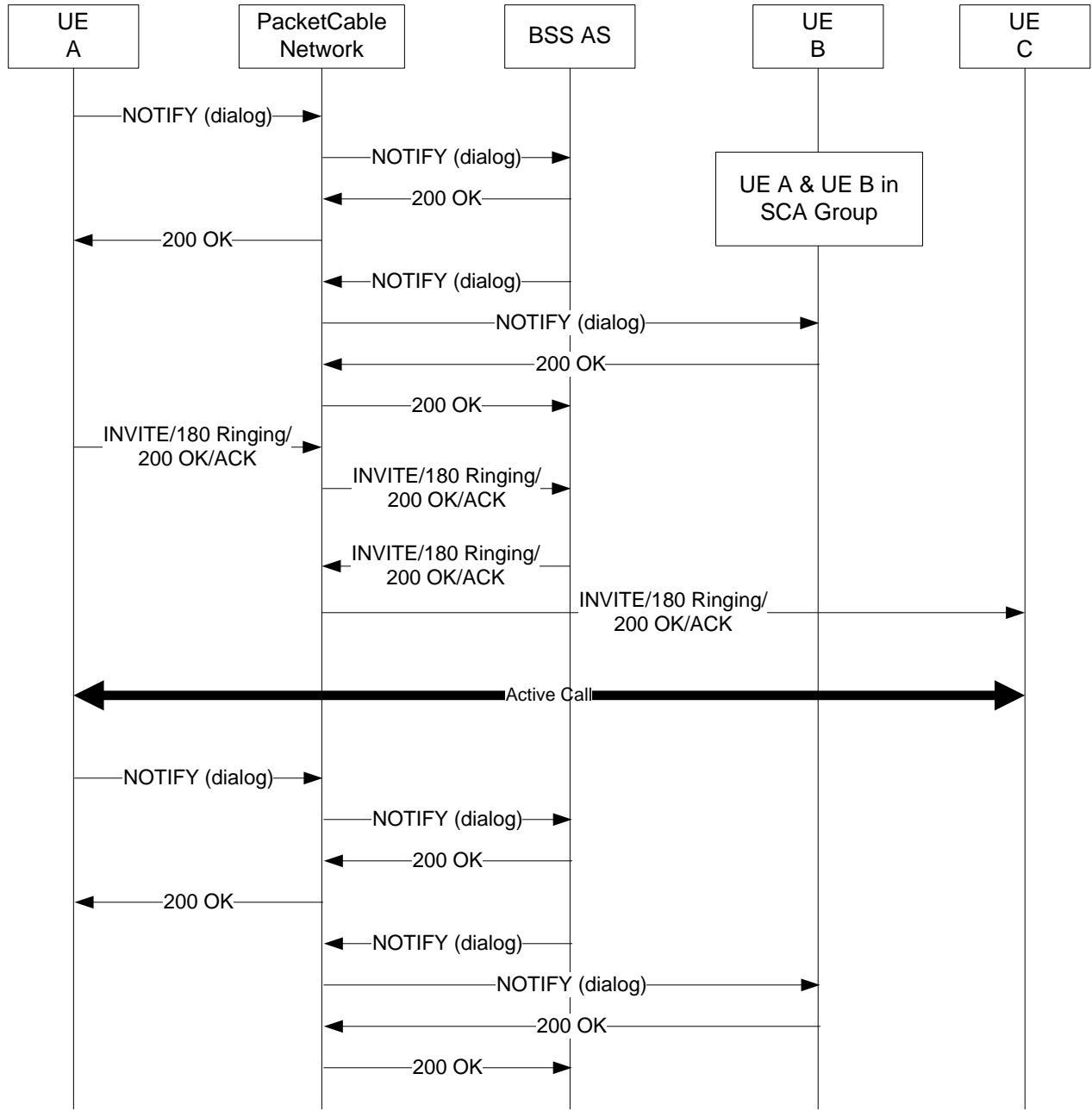

Figure 8 - SCA Call Origination

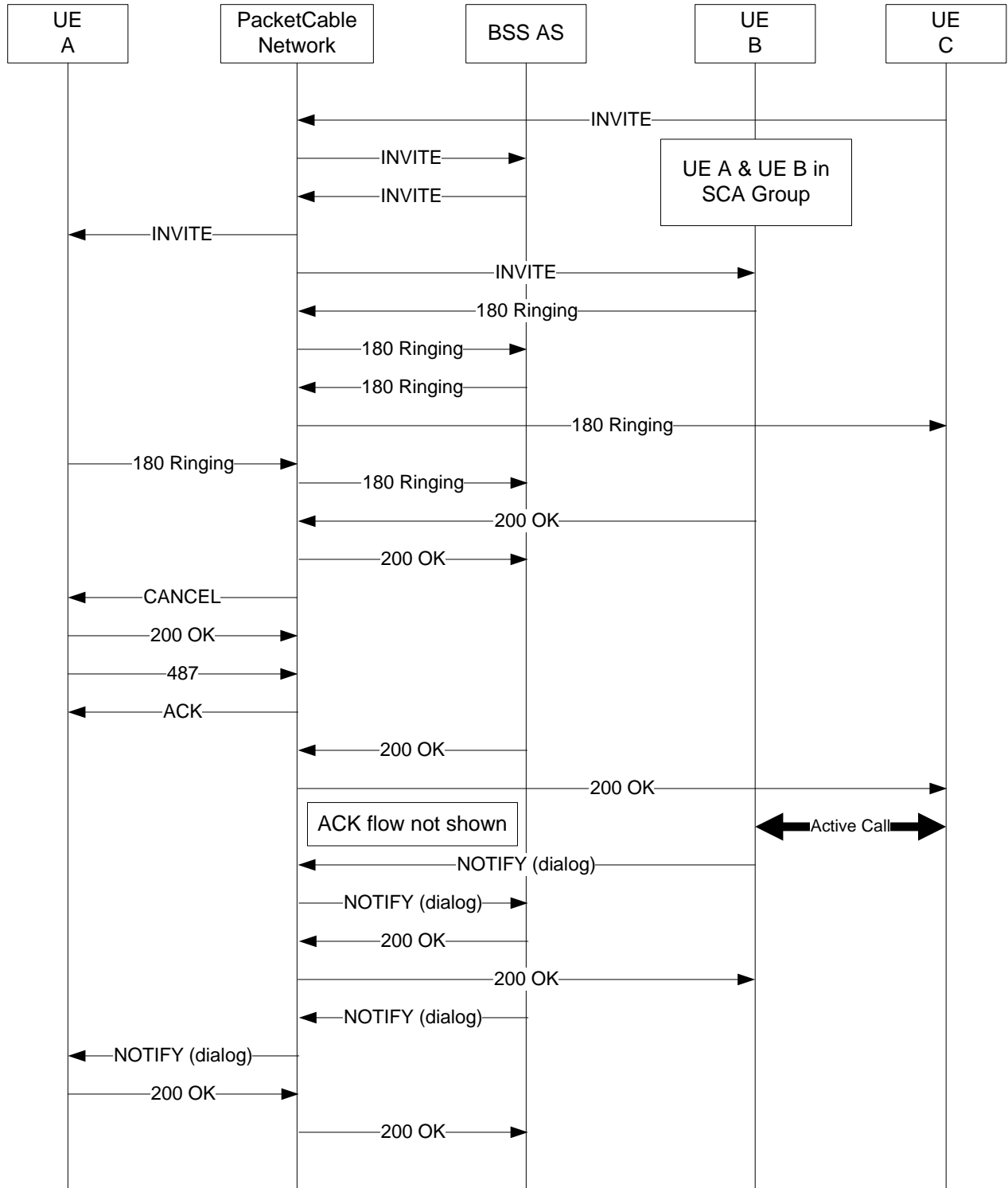

Figure 9 - SCA Call Termination

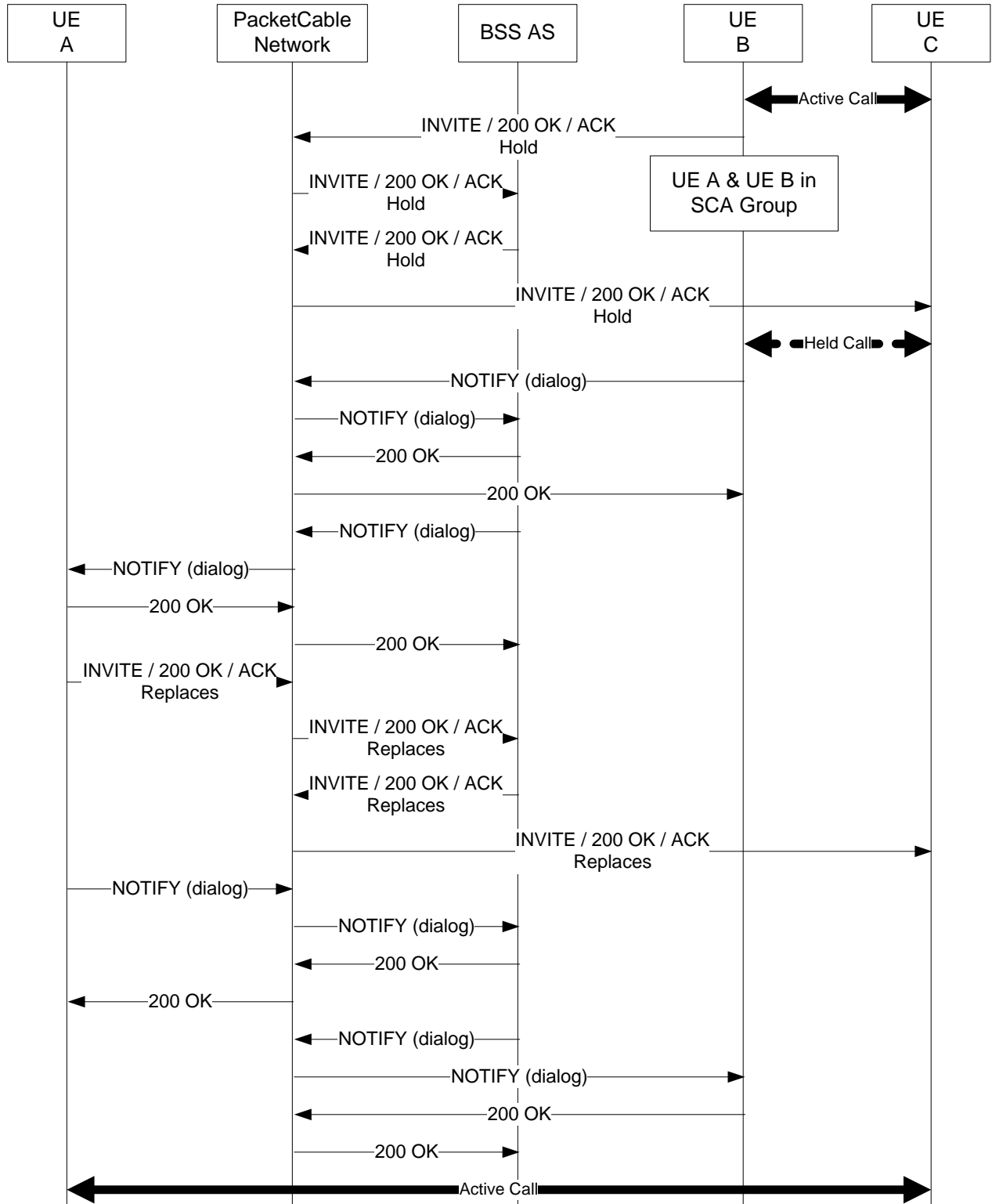

Figure 10 - SCA Call Hold/Retrieve

## 7.9.7 Shared Call Appearance Bridging (Multi-Location Shared-Line Appearance)

Shared Call Appearance Bridging allows a second terminal to barge in ("bridge") onto the existing active shared call appearance.

### 7.9.7.1 Feature Execution

Shared Call Appearance Bridging is an extension to Shared Call Appearance and requires that both the UE and BSS AS fully support requirements from Section 7.9.6.

Once an SCA member is involved in an active session, the session is available for bridging by any member of the group, if configured. In addition, all the SCA UEs and the BSS AS MUST support [RFC 3911].

1. A member's UE bridges the session by initiating an INVITE, including the Join header. The contents of the Join header is taken from the recent dialog notification associated with the call appearance that is being retrieved. The Request URI in the INVITE identifies the GRUU of the SCA UE with the active call to be bridged, but filter criteria configured in the PacketCable network routes the INVITE to the BSS AS.
2. Upon receiving the INVITE, the BSS AS may take one of the following actions:
  - The BSS AS may set up a conference call among the remote party, the initial UE (involved in the active session) and the UE requesting the bridge. Acting as a B2BUA, the BSS AS analyzes the JOIN header to determine which call appearance the UE is attempting to retrieve. The BSS AS issues the appropriate SIP methods to connect the sessions to a network-based conferencing resource
  - The BSS AS may relay the INVITE with JOIN directly to the SCA member UE originally involved in the active session. This method may be used in scenarios where two-appearance bridging is performed directly in the UEs as opposed to the network.
  - If two appearances are already bridged, the BSS AS may set up a conference call among the remote party, the initial UE, the original UE requesting the bridge, and the new UE requesting the bridge.
  - If three appearances are already bridged, the BSS AS may add the new UE requesting the bridge to the existing conference call.
  - If the requested session is no longer active, the BSS AS will issue a 4xx response.

Each terminal that shares a call appearance has a provisioned Boolean data item for each appearance that controls whether other terminals sharing the call appearance can bridge into calls to/from this terminal. This data item is provisioned to a value of "private" or "public", where bridging is blocked on private calls and allowed on public calls. The user of the terminal can override the provisioned value (for example, flip it from public to private) on a per-call basis. If this value is set to "private", the terminal rejects both INVITE with JOIN and conference requests with the isFocus indicator with a 603 Decline response.

Only a two-party call can be marked private on-per-call basis. After a third party (a second shared call appearance) has been bridged onto the call, the UE will no longer honor per-call privacy requests. A shared call appearance can only be bridged when that call is stable; that is the call appearance state is active. If the call is in any other state for the shared call appearance, the BSS AS will respond to the bridging attempt with a 4xx response.

### 7.9.7.2 Feature Data

Table 5 summarizes the feature data items that are defined in the UE to support the shared call appearance bridging feature.

**Table 5 - Shared Call Appearance Bridging UE Data**

Data	Type	UE Persistence	Scope	UE Provisioning
Default SCA Terminal Appearance Privacy	Enumerated ("private", "public")	Non-volatile	Per SCA per terminal	Optional Writable

**7.9.7.3 Call Flows**

Figure 11 shows an example call flow for Selective Call Appearance Bridging.

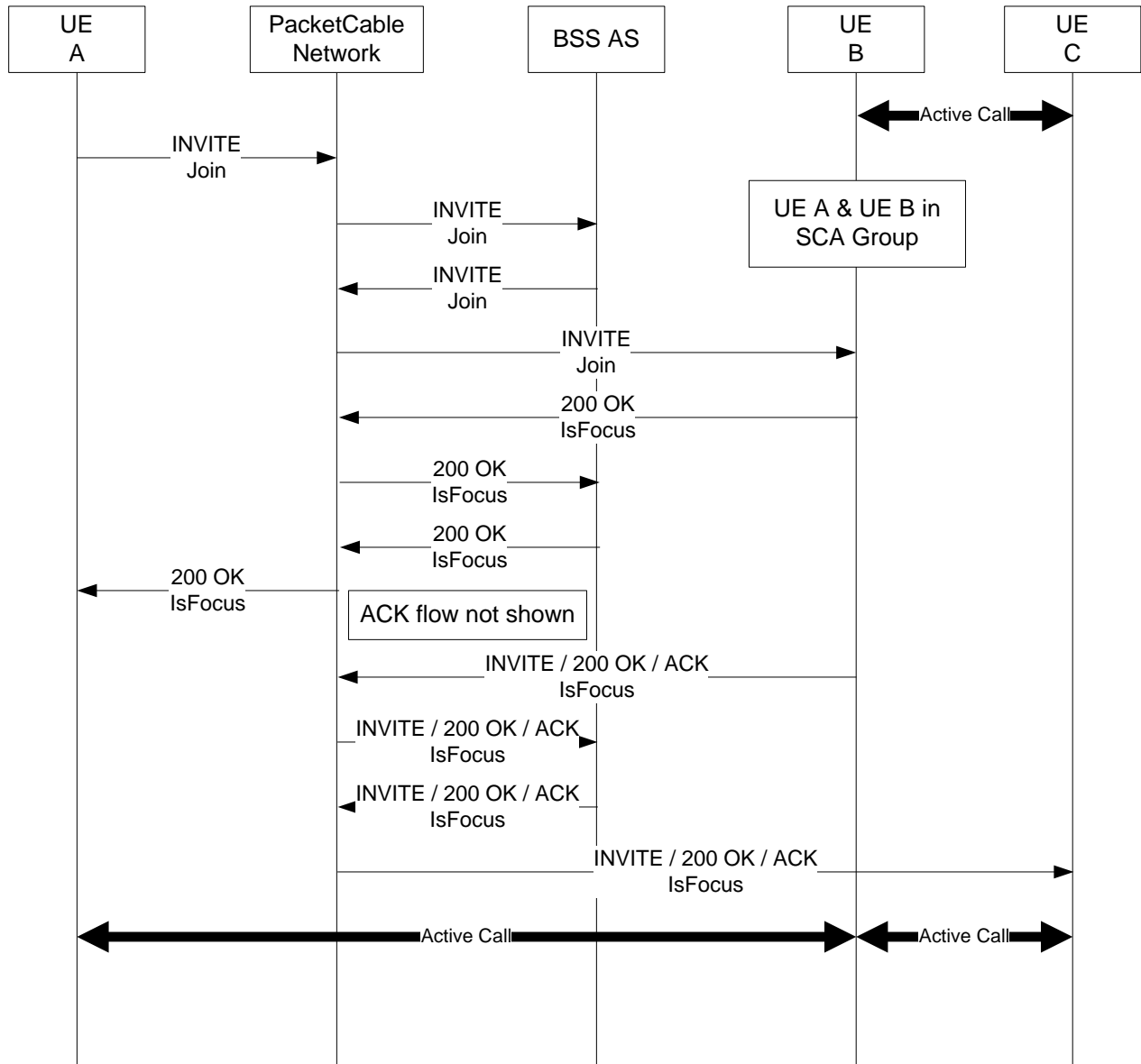

**Figure 11 - SCA Bridging**

**7.9.8 Sequential Ring**

The Sequential Ringing feature allows a user to have incoming calls presented to a list of phone numbers (or other identities). Each number in a ringing list is called in turn until the call is answered. Numbers in the ringing list may be outside the PacketCable domain (e.g., may be in the PSTN).

**7.9.8.1 Feature Execution**

**7.9.8.1.1 BSS AS**

The Sequential Ringing feature is entirely provided by the BSS AS. An example set-up sequence for the BSS AS is listed below.

1. Upon receipt of an INVITE destined to a public user identity for which Sequential Ringing is active, the BSS AS sends an INVITE towards the first address in the ringing list (typically the user's public user identity). If the call is answered (200 OK received), the call is connected and further operation of the processing stops.
2. If a no-answer timer expires or a final negative response is received (e.g., 486 Busy), the BSS AS sends an INVITE towards the next address in the ringing list. The BSS AS is also responsible for cancelling SIP dialogs for which no final response has been received.
3. The process is repeated until the caller is connected or all the numbers in the list are exhausted.

When the BSS AS sends an INVITE to a destination that does not correspond to the user, the BSS AS MUST use the procedures defined in Section 6.3.1 to detect and prevent forwarding loops.

### **7.9.9 Simultaneous Ring**

The Simultaneous Ringing feature allows a user to have incoming calls presented to a list of phone numbers (or other identities). Each number in a ringing list is alerted simultaneously until the call is answered. Numbers in the ringing list may be outside the PacketCable domain (e.g., may be in the PSTN).

#### **7.9.9.1 Feature Execution**

##### **7.9.9.1.1 BSS AS**

The Simultaneous Ringing feature is entirely provided by the BSS AS. An example set-up sequence for the BSS AS is listed below.

1. Upon receipt of an INVITE destined to a public user identity for which Simultaneous Ringing is active, the BSS AS sends an INVITE towards each address in the ringing list.
2. The first address that responds with a final successful response will be connected with the originating subscriber. Once the call is connected, the BSS AS is responsible for cancelling SIP dialogs for which no final response has been received.

When the BSS AS sends an INVITE to a destination that does not correspond to the user, the BSS AS MUST use the procedures defined in Section 6.3.1 to detect and prevent forwarding loops.

### **7.9.10 Call Push, Call Pull (Call Jump)**

Call Jump is a feature that enables the continuity of a call between defined devices associated with a subscriber. The call can either be "pulled" (that is the initiation takes place from the 'move to' device) or "pushed" (that is the initiation takes place from the 'move from' device).

From a user perspective, it allows procedures for a handover of calls between PacketCable devices and a standard cellular device, to which the user may be subscribed through any Mobile Network Operator (MNO). No pre-existing relationship is required between the MNO and the Cable MSO, except that its network is reachable.

#### **7.9.10.1 Feature Execution**

Call jump is only possible when the signaling for the target call is already anchored within the Business SIP service provider network. This will be the case for all outgoing calls from on-net devices and from all incoming calls targeted at the Business SIP identity of the user. Mechanisms to anchor calls for outgoing calls from the user's PSTN devices that are part of the jump group are outside of the scope of this specification.

Invocation of a Call jump (either pull or push) is only possible from a device that receives service from the Business SIP service provider. Mechanisms to invoke Call jump from a device, such as a mobile phone, that are part of the jump group are possible; however, the details of such a service are outside the scope of this specification.

##### **7.9.10.1.1 Call Termination**

Calls to the subscriber's primary identity also alert all devices in their associated call jump group using the Sequential Ring (Section 7.9.8) or Simultaneous Ring (Section 7.9.9) features.

### 7.9.10.1.2 Call Push

#### 7.9.10.1.2.1 UE

The user initiates Call Push by dialing a dedicated VSC followed by the Push Target. The subsequent execution of Call Push may then be viewed as a special case of blind Call Transfer with the transfer target being the push-to device. Hence, the UE MUST follow the requirements covering Call Transfer as defined in Section 7.4.5.

#### 7.9.10.1.2.2 BSS AS

The BSS AS MUST follow the general requirements covering Call Transfer as defined in Section 7.4.5.

### 7.9.10.1.3 Call Pull

#### 7.9.10.1.3.1 UE

The user initiates Call Pull by dialing a dedicated VSC from an idle device that is part of the call jump group. The UE MUST present an INVITE to the network containing the VSC as the RequestURI (see Section 6.4.1).

#### 7.9.10.1.3.2 BSS AS

An example set-up sequence for the BSS AS is listed below.

1. The BSS AS receives the INVITE and validates the request. If an active call is found, then the BSS AS determines the target of the Call Pull to be the other party involved in the active call with the device that is part of the call jump group. The BSS AS may then do one of the following:
  - The BSS AS then proxies the INVITE from the call jump invoker to the target having first included a Replaces header in the INVITE identifying the dialog of the active call, or
  - The BSS AS places the call leg to the target on hold. The BSS AS then releases the call leg to the device that is part of the jump group. Using 3PCC techniques, the BSS AS re-INVITES the target device with the offer SDP in the INVITE from the invoking device. On reception of the 200 OK with SDP from the target, this is provided as the final response to the invoking device and media is established between invoker and target.
2. The BSS AS may choose to provide the invoking call leg with progress media indicating that the pull attempt is ongoing.

**7.9.10.2 Call Flows**

Figure 12 shows an example call flow for an incoming call to a Call Jump subscriber.

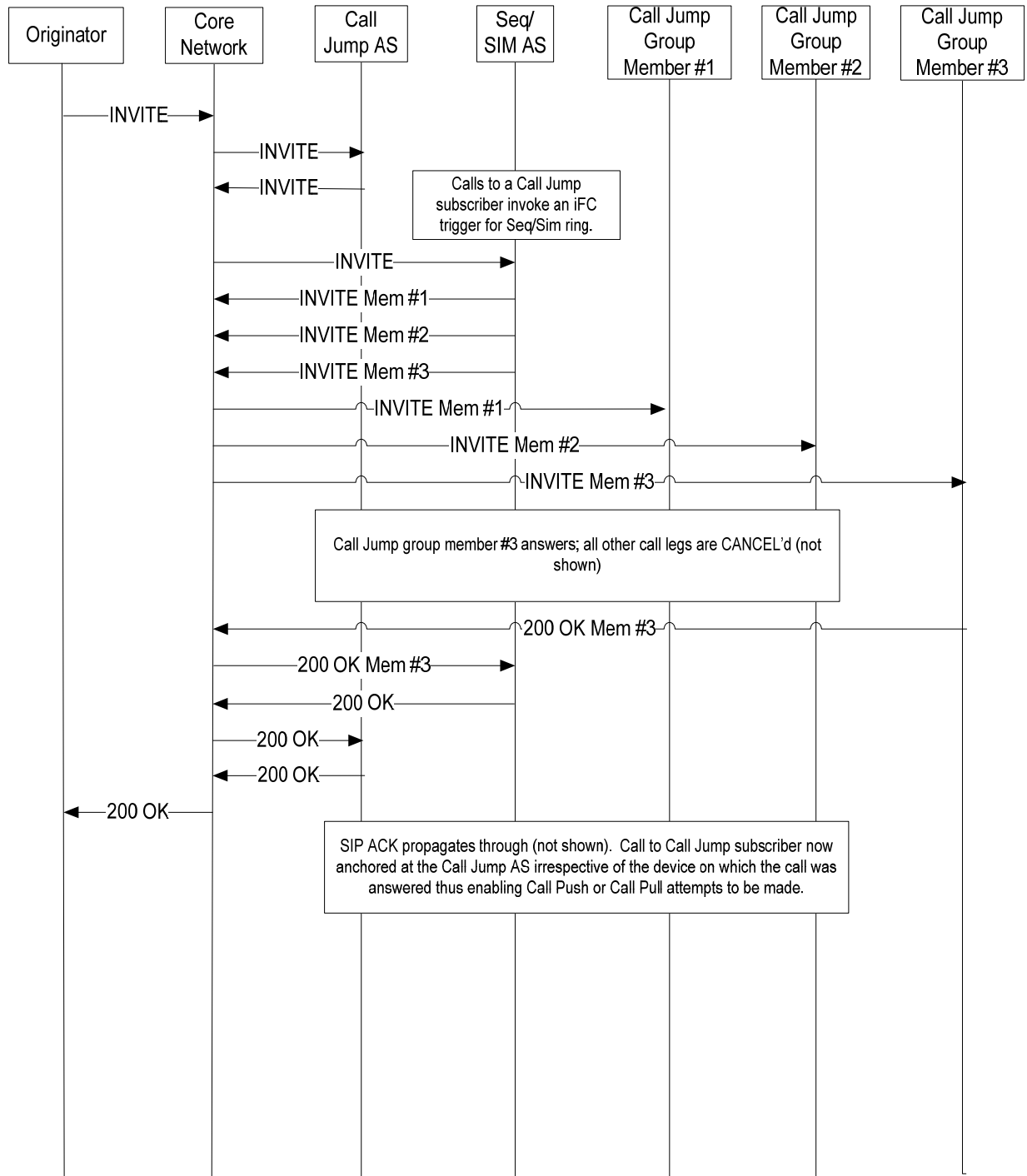

**Figure 12 - Call Jump; Incoming Call to Call Jump Subscriber**

Figure 13 shows an example call flow for the execution of Call Pull making use of the Replaces header.

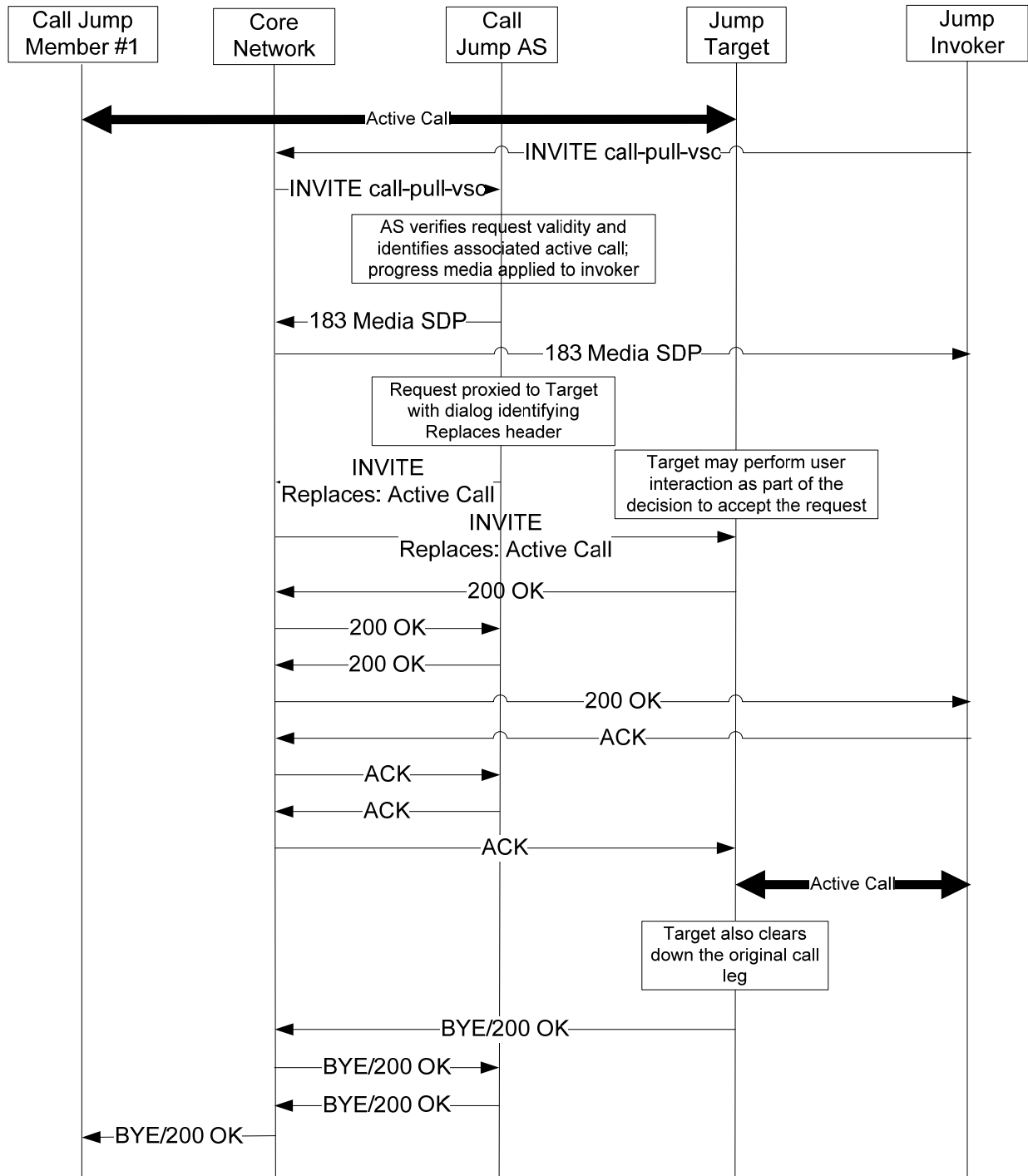

Figure 13 - Call Jump; Call Pull Using Replaces

Figure 14 shows an example call flow for the execution of Call Pull making use of 3PCC techniques.

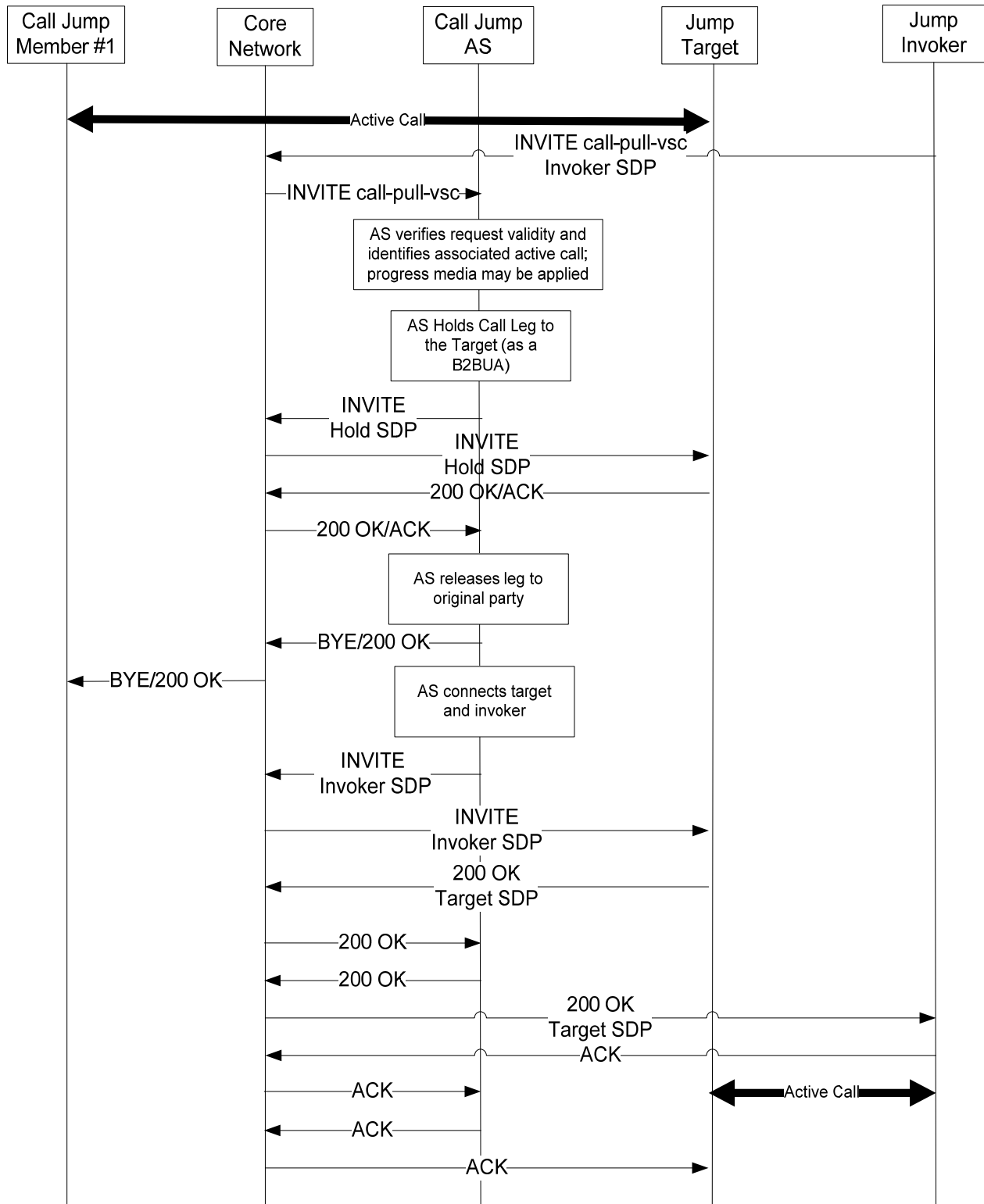

Figure 14 - Call Jump; Call Pull Using 3PCC Techniques

## 7.10 Business-Oriented Group Line Features

### 7.10.1 Account Codes

The Account Codes Service feature allows the subscriber to enter a special digit sequence (the account code) that is reflected in the billing record generated for the call. This enables the tracking and categorization of calls made or received by the subscriber.

#### 7.10.1.1 Feature Execution

##### 7.10.1.1.1 Assigning Account Codes on call origination

The Account Codes feature is mainly provided by the BSS AS, with the UE only required to support the minimum profile defined in Section 6.2.

The Account Codes feature can be triggered in one of two methods.

##### 7.10.1.1.1.1 User dials VSC

###### 7.10.1.1.1.1.1 UE

The UE originates a call destined to the Account Codes VSC using the procedure defined in Section 6.4.1.

###### 7.10.1.1.1.1.2 BSS AS

The BSS AS receives the INVITE for the call. Using early media (Section 6.4.2) and network-based media resources, the BSS AS prompts the user to enter the account code and the destination for the call. The BSS AS allows the call to proceed towards the intended destination. The BSS AS provides details of the account code to the billing system.

##### 7.10.1.1.1.2 AS prompts for account code

###### 7.10.1.1.1.2.1 UE

The UE originates a call to the required destination as normal.

###### 7.10.1.1.1.2.2 BSS AS

The INVITE is routed using an originating trigger to the BSS AS. The BSS AS analyses the Request URI to determine whether the called destination requires an account code. If an account code is required, the BSS AS uses early media (Section 6.4.2) and network-based media resources to prompt the user to enter the account code. The BSS AS allows the call to proceed towards the intended destination. The BSS AS provides details of the account code to the billing system.

##### 7.10.1.1.2 Assigning Account Codes during a call

**Problem Statement:** After a VSC is entered mid-call, the UE sends an INVITE to the BSS AS, and the account code is gathered by the BSS AS. The BSS AS prompts the user to enter the account code and the destination for the call using early media, as per Section 7.10.1.1.1.

- If the user flashes again before entering a destination, the leg to the BSS AS should be dropped, and the UE should go back to the current call to which the account code will be applied. It seems that the UE should, therefore, be aware that this was an account code consultation, since a flash would normally create a conference. It could also be difficult for the BSS AS to identify the call to which the account code should apply.
- If the user enters a destination before flashing, then flash should establish a normal conference call, and the account code will only apply to the new leg. How is the UE to distinguish between this case and the previous case?

##### 7.10.1.1.2.1 UE based approach

In order to handle Account Codes during mid-call, it is possible to design the intelligence in the UE, at a minimum, to include enough information in the INVITE for the billing system to correlate the Account Code with the current call, and preferably to perform much of the Account Code logic on the UE with full support of featured sets. The drawback of this approach is that UEs incorporating this design would have to be built, subjecting the availability of this feature to development cycle and to business decision to build them.

This approach is outside the scope of this specification.

#### 7.10.1.1.2.2 AS based approach

In order for mid-call Account Codes to work with existing UEs including RST capable UEs, all INVITEs to or from public user identities subscribed to the Account Codes feature will be routed to the BSS AS so that it is aware of all calls on the UE.

Limitation: A mid-call Account Code can only be entered when there is only a single established call on the UE.

##### 7.10.1.1.2.2.1 UE

When the user flashes and dials the account code VSC, the UE places the current call on hold and establishes a consultation call (Section 7.4.4).

##### 7.10.1.1.2.2.2 BSS AS

The BSS AS will gather the account code and destination as per Section 7.10.1.1.1. If no destination is intended, the user will enter a "#" to indicate this to the BSS AS, which will then release the VSC leg, and the call is resumed as per Consultation Hold (Section 7.4.4).

If the user flashes without entering a destination and without entering a "#", then a conference is established, the BSS AS releases the VSC leg when it detects that the current call has resumed, and the media attributes of the call are now sendrecv.

If the user disconnects the call, the current call is resumed as per Consultation Hold (Section 7.4.4).

## 7.10.2 Authorization Codes

The Authorization Code service allows the subscriber to enter a special digit sequence (the authorization code), and thereby replace, for a single call, the restrictions assigned to the user with the restrictions assigned to the authorization code. The authorization code service can be used to override Outbound Call Restrictions (Section 7.10.6). Authorization codes can be unique to a given user, or shared within a department. Different codes (each which facilitate different dialing privileges) could be dialed from any line.

### 7.10.2.1 Feature Execution

Authorization Code feature execution is very similar to Account Codes (Section 7.10.1.1.1), except that the call is not allowed to proceed unless a valid Authorization Code is provided.

## 7.10.3 Hunting and Hunt Groups

Hunting is a terminating service that selects an idle (registered and non-busy) member of a provisioned group of users (the hunt group) to receive an incoming call. Inbound calls to the pilot number of the hunt group are distributed across the members of the group using a specific hunting algorithm. Ultimately one idle member of the group is selected to receive the call, and the call is offered to that member. If a member of the group is busy, hunting proceeds to select the next available member to receive the call. In scenarios where all members of the group are busy, the group can be configured with an overflow destination or treatment to which the incoming call is routed.

### 7.10.3.1 Feature Execution

#### 7.10.3.1.1 BSS AS

The Hunt Group feature is provided by the BSS AS. The logic specified in this document for the hunting service stipulates that all members of the hunt group are associated with the same BSS AS that supports hunting. An example set-up sequence is listed below.

1. INVITEs addressed to the pilot DN (address) of the hunt group are routed to the BSS AS.
2. The BSS AS identifies a candidate member of the group to which the call can be offered according to the hunt algorithm in effect. From [GR 569], calls should only be offered to an idle member (one that is not currently involved in a call, even if this member could accept another call using a service like Call Waiting). This requires that the BSS AS maintains knowledge of active sessions that it has offered to each of the members of the group (and ideally sessions initiated by the hunt member).

3. The BSS AS then offers the call to the candidate member by sending an INVITE. The headers of the INVITE are constructed such that the member's URI is reflected in the request-URI, and the pilot number associated with the hunt group is reflected in the to-URI. It's not expected, though, that the UE will leverage the contents of the to-URI when presenting the call to the user. If the intent is for the UE to specifically notify the user of calls associated with the hunt group, then the UE should be configured with two public identities: one that is associated with the hunt group (and likely not published externally), and a second that is used whenever calls terminate directly to the subscriber (independent of the hunt group).
4. The INVITE is received by the member's UE. At this point one of two events could occur:
  - The terminating UE accepts the INVITE and returns a 180 RINGING response. This response is propagated through to the originating party. Upon answering the call, the terminating UE will propagate a 200 OK response to the originating party. The BSS AS will maintain state information around the active session until it is released.
  - The terminating UE (or the core network in the case where the member isn't registered) rejects the call through a 4xx or 6xx response to the INVITE. In this scenario, the response is propagated back to the BSS AS, and the BSS AS repeats the above process for the next idle candidate member.

The messaging associated with the hunting service can be made more efficient if the BSS AS subscribes to the reg event package with the PacketCable core network for each member of the group. With registration notifications, the BSS AS is in a position to bypass non-registered members of the hunt group when executing the hunting algorithm. This eliminates the messaging overhead and latency of selecting non-registered members as termination candidates, only to have a rejection response returned to the BSS AS.

#### **7.10.4 Call Park and Directed Call Park**

The Call Park and Directed Call Park features enable a user to place a call on hold from one extension, and to subsequently retrieve it from another extension within the Business Group. The call is parked against a park-identifier, which is used to retrieve a call. The park-identifier may correspond to an extension or may be a virtual identifier.

##### **7.10.4.1 Feature Execution**

The Call Park and Directed Call Park features are mainly provided by the BSS AS, with the UE only required to support the minimum profile defined in Section 6.2.

###### *7.10.4.1.1 Parking a call*

###### 7.10.4.1.1.1 UE

A user connected on a stable call may park that call with Call Park or Directed Call Park.

In order to request that the call be parked, the UE places the current call on hold and sends a SIP INVITE request containing the appropriate feature code (e.g., '\*77' + <park-identifier>). This operation is similar to Consultation Hold (Section 7.4.4), and is the first step of a Consultative Transfer (Section 7.4.5).

###### 7.10.4.1.1.2 BSS AS

An example set-up sequence is listed below.

1. The BSS AS receives the INVITE. Depending upon type of Call Park service, the BSS AS may connect this call to network-based media resources to collect additional information (e.g., a park identifier) or to notify the requesting (parking) user which park identifier the call has been assigned to.
2. The UE completes the Consultative Transfer (Section 7.4.5) to connect the remote party with the BSS AS and release the local session.
3. The BSS AS places the remote party "on hold" or provides suitable alternative media (e.g., Music On Hold – Section 7.4.3).

### 7.10.4.1.2 Retrieving a call

#### 7.10.4.1.2.1 UE

When a call is parked, a user may request to be connected to that call using Call Retrieve.

The UE sends a SIP INVITE request containing the Call Retrieve activation code and an optional park-identifier (Section 6.4.1).

#### 7.10.4.1.2.2 BSS AS

A call may only be retrieved from the BSS AS that processed the Call Park or Directed Call Park request for the call.

The BSS AS receives an INVITE and identifies the park-identifier (collecting digits if required). The BSS AS connects the parked party with the retrieving party.

## 7.10.5 Call Pickup Features

The Call Pickup feature consists of the following features that permit a UE to be connected to a call that was alerted to another line.

- The Group Call Pickup (CPU) feature enables a user to answer an unspecified ringing line within a Call Pickup group.
- The Directed Call Pickup (DPN) feature enables a user to answer a specific ringing line within a Business Group.
- The Directed Call Pickup with Barge-in (DPU) feature enables a user to answer a specific ringing line, or barge-in a call if the call is stable, and if the barged-in extension subscribes to the Directed Call Pickup with Barge-in termination feature.

### 7.10.5.1 Feature Execution

#### 7.10.5.1.1 UE

Call Pickup features are provided by the BSS AS. An example set-up sequence for picking up an alerting call is listed below.

The user initiates call pickup by dialing the appropriate feature code (e.g., '\*77' + <extension number>). The UE sends this feature code in an INVITE (Section 6.4.1).

#### 7.10.5.1.2 BSS AS

The BSS AS receives an INVITE with a Call Pickup activation code, and identifies the call to be picked up. For CPU, the BSS AS chooses any call that is alerting to a member of the user's Call Pickup group. For DPN and DPU, if there is a single alerting session, the BSS AS selects that session.

The BSS AS connects the UE with the selected call at the extension. The BSS AS also sends a CANCEL message to the target for the alerting session.

If a stable call was selected (for DPU), the BSS AS initiates the Barge-in process as follows. First, the BSS AS optionally injects an intrusion tone such as a 440 Hz Call Interrupt tone into the call. Then the BSS AS either sends an INVITE with a JOIN header to the Target extension or connects the parties to a network conference resource.

## 7.10.6 Outbound Call Restriction (Calling Plan Outgoing)

The Outbound Call Restriction (Calling Plan Outgoing) (OCR) feature provides selective Class of Service (COS) restrictions based on administrator provisioning. As a group feature, OCR is typically applied to a group of users, but no restrictions are placed against configuring this feature on an individual user basis.

### 7.10.6.1 Feature Execution

#### 7.10.6.1.1 BSS AS

OCR is provided by the BSS AS. Feature execution at the SIP level is similar to Outbound Call Blocking (see Section 7.3.1).

### 7.10.7 Charge Number Service

Charge Number Service allows Business Group Administrators to associate a charge number with an individual user or group.

#### 7.10.7.1 Feature Execution

##### 7.10.7.1.1 BSS AS

The BSS AS MUST populate the Alternate Charge Party Address in the CDR as defined in [TS 32.260] when Alternate Party Charging is provisioned for a user or group of users. The INVITE remains unchanged.

### 7.10.8 Loudspeaker Paging

The Loudspeaker Paging feature allows a caller to simultaneously address a group of users within a Business Group via a unidirectional voice path, i.e., a page. The loudspeaker paging feature is only applicable to UEs with auto-answer and loudspeaker capabilities. Integration with legacy paging systems and talkback abilities are outside the scope of this specification.

#### 7.10.8.1 Feature Execution

##### 7.10.8.1.1 UE

For loudspeaker paging to operate, a paged UE MUST support the auto-answer header as specified in Section 6.4.4 and contain a loudspeaker.

##### 7.10.8.1.2 AS

Upon receiving the specified VSC and Paging Group number, the BSS AS MUST create a unidirectional audio path from the caller to each user identity in the Paging Group. The BSS AS SHOULD verify that the Paging Group number is valid for the Business Group. The BSS AS MUST use the procedures defined in Section 6.4.4 to signal in the INVITE to each user identity in the Paging Group that the call is to be automatically answered.

An example set-up sequence for the BSS AS is listed below.

1. Reserve an N-way unidirectional conference bridge (n will be the number of users in the paging group + 1).
2. Send an INVITE using the public identity of the caller to each user in the specified Paging Group. Each INVITE contains an auto-answer header as specified in Section 6.4.4 with source SDP originating from a leg of the N-way bridge.
3. If at least one Paging Group UE returns ringing, the BSS AS will return ringing to the caller; otherwise an announcement will be played.
4. Paging Group UEs will be added to the n-way bridge as each UE returns 200 OK.
5. All unanswered calls will be canceled after a provisionable answer timeout delay.
6. Connect the caller to n-way bridge and return 200 OK.
7. Release any unused legs of the n-way bridge.
8. One-way audio is now active between caller and all answered UEs in the Paging Group.
9. Release all calls and n-way bridge when caller hangs up.

**Note:** The downstream bandwidth requirements for paging a large group of users may exceed the normal usage pattern for a BSS group. For example, if 20 BSS users were in a paging group, an equal number of downstream media streams would be needed for a page. It is expected that pages are normally short in duration.

**7.10.8.2 Call Flows**

Figure 15 assumes the N-way bridging function is contained in the BSS AS. The example call flow includes two paged users in the Paging Group.

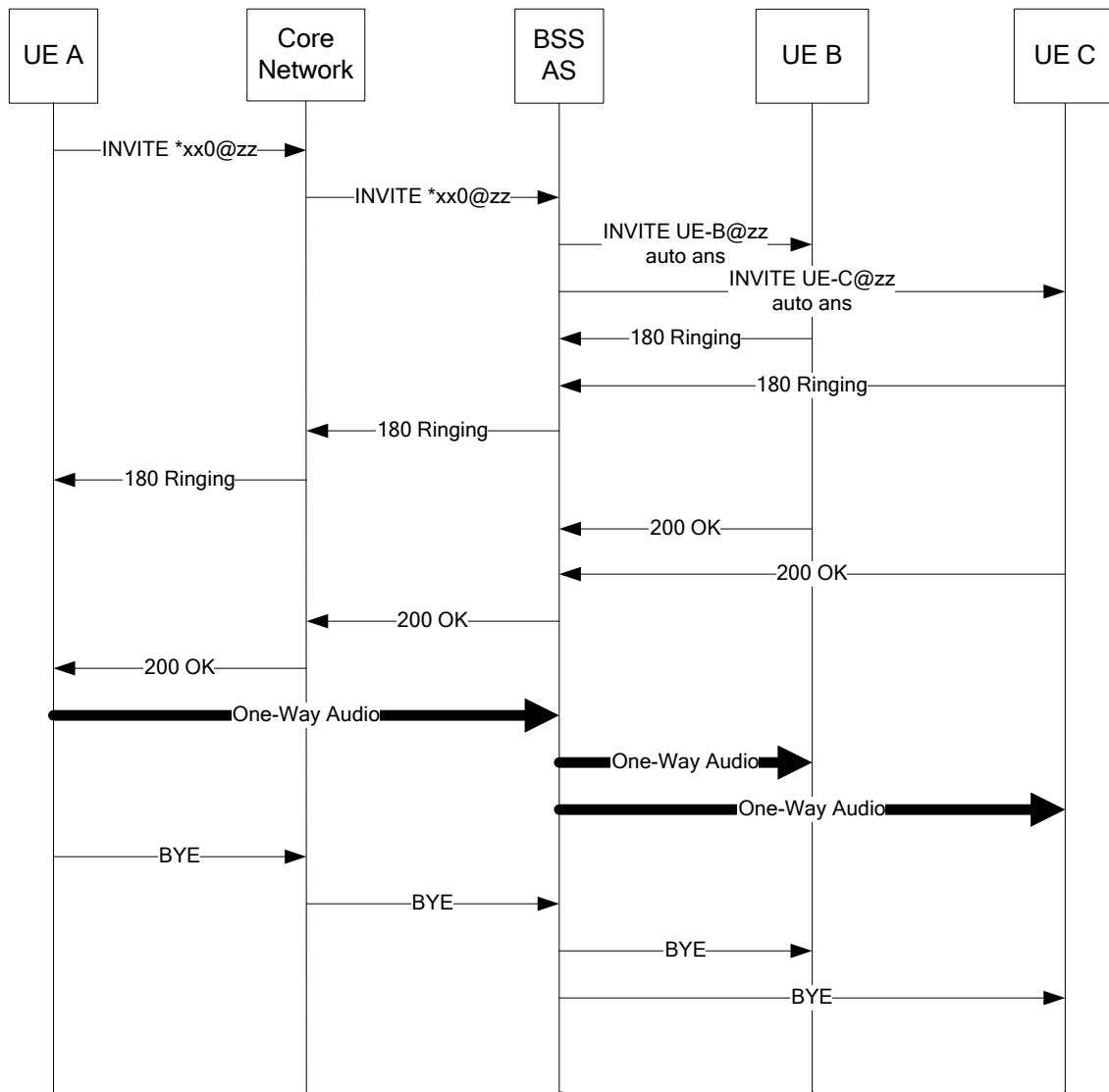

**Figure 15 - Loudspeaker Paging**

**7.11 Third Party Call Control Features**

Third Party Call Control (3PCC) refers to the use of a personal computer to provide graphical user interface functions for initiating calls from or interacting directly with calls received at telephones served by Business SIP Services.

Third Party Call Control is applicable to users who are equipped with any type of BSS UE, such as an analog handset or a SIP business phone. The Remote Office feature (Section 7.11.7) extends support to operate with any telephone capable of being called directly, such as a PacketCable 1.x device, a PacketCable RST UE, or a phone connected to the PSTN.

These features are provided by the BSS AS and places minimal requirements on the UE. It does not depend upon direct communications between personal computers and the UE, allowing these to be located on different network

segments. The communications path between the personal computer and the BSS AS is outside the scope of this specification.

### 7.11.1 Click-to-dial

The Click-to-Dial feature allows a user to initiate a new call from their personal computer.

#### 7.11.1.1 Feature Execution

##### 7.11.1.1.1 BSS AS

It is recommended that implementers consider guidance contained within [RFC 3725], which also shows some example click-to-dial call flows. An example sequence is listed below.

1. The click-to-dial feature is invoked from a user's computer, resulting in a click-to-dial request being received by the BSS AS.
2. The BSS AS sends an INVITE to the user's UE. The BSS AS MAY request that the call is automatically answered using the mechanism specified in Section 6.4.4. The BSS AS MAY request that a special ringing cadence is played by including an Alert-Info header (Section 6.4.3).

**Note:** The feature degrades gracefully if the UE does not support [RFC 5373] or the Alert-Info header. In this case, the user's phone rings normally and the user needs to manually go off-hook.

3. When the first call is answered, the BSS AS establishes a call to the target and connects the call to the user.

### 7.11.2 Incoming Call Notification and Control

The Incoming Call Notification feature displays details of the call on the user's personal computer. The user is also able to dynamically control the alerting incoming call (e.g., forwarding the call to another line or to voicemail).

#### 7.11.2.1 Feature Execution

##### 7.11.2.1.1 BSS AS

An example sequence is listed below.

1. Calls placed to the user's public identity are routed via the BSS AS.
2. The BSS AS allows the call to ring the subscriber's UE as normal. The BSS AS also notifies the computer application with details of the call, such as the caller's identity.

One of the following things might then occur:

- The call is answered (200 OK) or another final response is seen. The BSS AS notifies the computer application (e.g., to hide the incoming call notification).
- The user selects one of the incoming call control options offered by the application, and the application sends a request to the BSS AS. The BSS AS invokes appropriate service logic for the request. For example, to deflect the call to voicemail, the BSS AS sends a CANCEL to the UE to stop the user's phone from ringing and then forwards the call to the voicemail system (see Section 7.2).

Since the user's computer operates outside the trust domain of the network, the BSS AS MUST NOT disclose the identity of an anonymous caller to the computer.

#### 7.11.2.2 Call Flows

Call flow details are left to the designer of the BSS AS. Figure 16 illustrates an example call flow for the case where the subscriber deflects the call to voicemail. For brevity and clarity, the terminating PacketCable Networks (CSCFs etc.) and some SIP responses/ACKs are not shown.

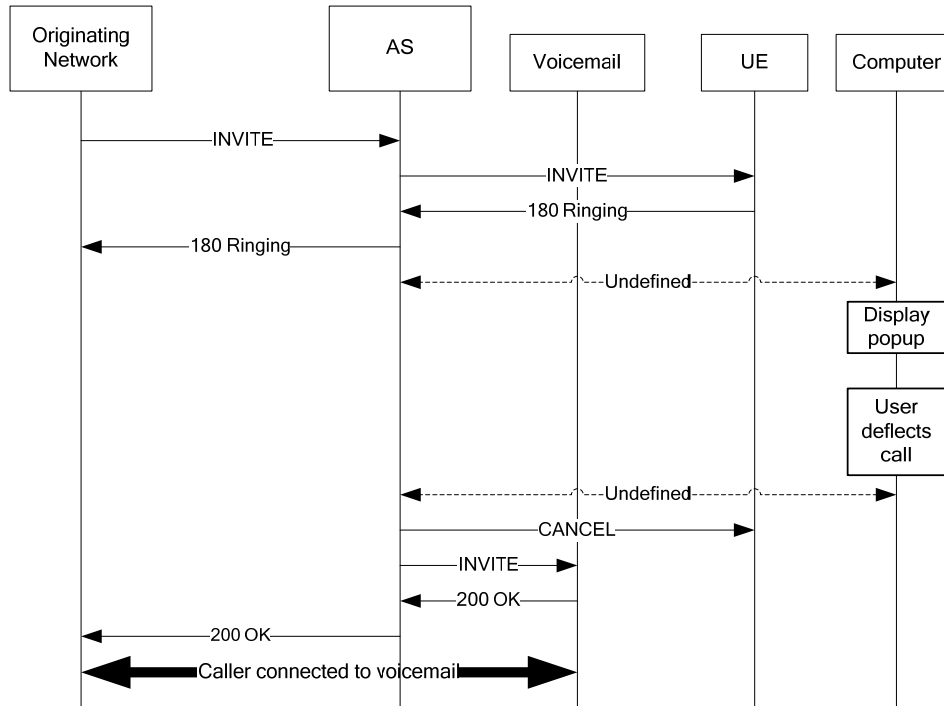

**Figure 16 - Incoming Call Notification and Control**

### 7.11.3 3PCC Call Hold/Retrieve

The 3PCC Call Hold/Retrieve feature allows the user, through their computer, to place an active call on hold and to later retrieve a call using 3PCC.

#### 7.11.3.1 Feature Execution

##### 7.11.3.1.1 BSS AS

An example sequence is listed below.

1. The Call Hold feature is invoked from a user's computer, resulting in a call hold request being received by the BSS AS.
2. The BSS AS then places the media for the call on hold, for example by sending re-INVITE to both ends with `a=inactive` in the SDP. Alternatively the BSS AS may provide music on hold media to the far end (Section 7.4.3).
3. When the BSS AS receives a user request to retrieve a previously held call, it sends re-INVITES to both parties to connect the media from the far end with the call leg to the user's UE.

While the BSS AS may be able to detect when a call is held locally on the UE by monitoring the SIP flows for on-hold SDPs (see [RSTF] for hold SDP details), there is no standard mechanism available in SIP that allows the BSS AS to retrieve a call held by the UE. It is recommended that a user does not attempt to use 3PCC Call Hold at the same time as local multi-party features.

### 7.11.4 3PCC Call Transfer

The 3PCC Call Transfer feature allows the user, through their computer, to transfer a call.

### **7.11.4.1 Feature Execution**

#### **7.11.4.1.1 BSS AS**

The call transfer feature is invoked from a user's computer. The exact behavior of the BSS AS is heavily dependent upon the design of the computer application and its user interface, for example in the way in which a consultation call is established. The BSS AS may make use of the Call Transfer flows described in Section 7.4.5.

### **7.11.5 3PCC Conferencing**

The 3PCC Conferencing feature allows the user, through their computer, to establish a multi-party call by adding a new party or previously held call to an active call.

#### **7.11.5.1 Feature Execution**

##### **7.11.5.1.1 BSS AS**

An example sequence is listed below.

1. The BSS AS receives a request from a user's computer to add a new party to an existing call.
2. If the call is not already in a conference, the BSS AS re-INVITEs both existing parties to connect their media with a network-based conferencing resource.
3. The BSS AS sends an INVITE to the new party, connecting media for this call legs with the network-based conferencing resource.

**Note:** The BSS AS is unlikely to be able to detect when a UE is locally implementing a three-way call (see Section 7.4.6). It is recommended that a user does not attempt to use 3PCC Conferencing at the same time as local three-way calling features.

### **7.11.6 3PCC Release Call**

The 3PCC Release Call feature allows a user to release a call (or call leg) using their computer.

#### **7.11.6.1 Feature Execution**

##### **7.11.6.1.1 BSS AS**

An example sequence is listed below.

1. The BSS AS receives a request from a user's computer to release an existing call.
2. The AS releases a call by sending an in-dialog BYE to the party to be released.

### **7.11.7 Remote Office (Satellite Office, Road Warrior)**

The Remote Office feature provides a user with the means to access all of the voice services and calling features that are available on his Business SIP Services line from a remote location that is equipped only with a computer that has Internet access, and a telephone that is capable of receiving incoming calls directly (which may be a cell phone).

#### **7.11.7.1 Feature Execution**

##### **7.11.7.1.1 BSS AS**

When Remote Office is enabled, the BSS AS forwards incoming calls and the first call leg of click-to-dial calls to the remote phone instead of presenting the call to the user's normal phone. This uses a similar underlying mechanism as Call Forwarding Variable (Section 7.2.1), and the BSS AS MUST prevent forwarding loops using the mechanism described in Section 6.3.1.

## Annex A Device Requirements

This Annex defines non-SIP requirements for BSS UEs without any analog interface. Such requirements for BSS UEs with analog interfaces are included in [E-DVA].

### A.1 DTMF Transport

The UE MUST support the relay of the following DTMF digits as part of an established session: 0-9 \*, #.

The UE MUST apply DTMF tone to the audio path, or generate DTMF relay per [CODEC MEDIA] as dictated from the negotiated SDP associate with the session. The UE MUST offer DTMF relay within SDP upon session origination unless local UE provisioning (Table 6) indicates otherwise.

**Table 6 - DTMF Relay Feature Data**

Data	Type	UE Persistence	Scope	UE Provisioning
DTMF Relay	Boolean	Non-volatile	Per Business Group	Optional Writable

### A.2 Monitoring and Management

#### A.2.1 In-Service and Out-of-Service States

In the PSTN, dial tone indicates to the user that the phone is connected to the network when the phone goes off-hook. In the BSS environment, equivalent network connectivity is determined by the UE in-service and out-of-service states. If the UE is in-service, it provides appropriate indication to the user that the UE is available for a call; otherwise, it indicates to the user that a call cannot be initiated. For example, a UE with analog interface plays a dial tone to the user when the phone goes off-hook, if, and only if, the UE is in the in-service state.

Furthermore, in the PSTN, if the network is not available for service, the DC voltage bias on the analog line is lowered. The traditional alarm system relies on the detection of the DC voltage bias on the analog line to determine if the network is in service. In the BSS environment, since the alarm systems can be connected to the UEs with analog interfaces, such UE devices need to emulate the similar DC voltage control on its analog interfaces by detecting in-service and out-of-service states.

All BSS UEs SHOULD comply with the requirements on In Service/Out Of Services States in [RSTF].

#### A.2.2 VoIP Metrics

All BSS UEs SHOULD comply with the requirements on voice metrics in [CODEC MEDIA].

## Appendix I Acknowledgements

PacketCable wishes to recognize the following individuals for their significant involvement and contributions to this specification (ordered alphabetically by company name and individual's first names in each company):

Mike Emmendorfer, Arris

Gordon Li, Broadcom

Pete Quigley, Cedar Point

Rob Lund, Cedar Point

Eric Turcotte, Ericsson

Mark Stewart, MetaSwitch (Lead Editor)

Johannes Schoepf, Nokia Siemens

Bill Gentry, Nortel Networks Cable Solutions, Inc.

Guy Vonderweidt, Nortel Networks Cable Solutions, Inc.

Mark Trayer, Samsung (Lead Editor)

Rajeev Seth, Sonus

Richard Wikoff, Sonus

Geoff Devine, Whaleback Systems

The following CableLabs staff is thanked for their indirect contributions that helped us improve this specification in various ways: Kevin Johns, Glenn Russell, and David Hancock.

*Sandeep Sharma and the PacketCable Architecture Team (CableLabs)*

## Appendix II Revision History

The following Engineering Change Notices were incorporated in PKT-SP-BSSF-I02-100120.

<b>ECN</b>	<b>ECN Date</b>	<b>Summary</b>
BSSF-N-08.0539-1	3/16/09	Remove Annex A (Device Requirements)
BSSF-N-09.0554-4	11/23/09	Update IETF references